

GSMDS6808

60V Dual N-Channel MOSFETs

Product Description

These Dual N-Channel enhancement mode power field effect transistors are using trench DMOS technology. This advanced technology has been especially tailored to minimize on-state resistance, provide superior switching performance, and withstand high energy pulse in the avalanche and commutation mode.

These devices are well suited for high efficiency fast switching applications.

Features

- 60V, 10A, $R_{DS(ON)}=34m\Omega@V_{GS}=10V$
- Improved dv/dt capability
- Fast switching
- 100% EAS Guaranteed
- Green Device Available
- SOP-8 package design

Applications

- Motor Drive
- Power Tools
- LED Lighting

Packages & Pin Assignments

GSMDS6808SF (SOP-8)	
 <p style="text-align: center;">Top View</p>	
Pin	Description
1	Source 1
2	Gate 1
3	Source 2
4	Gate 2
5	Drain 2
6	Drain 2
7	Drain 1
8	Drain 1

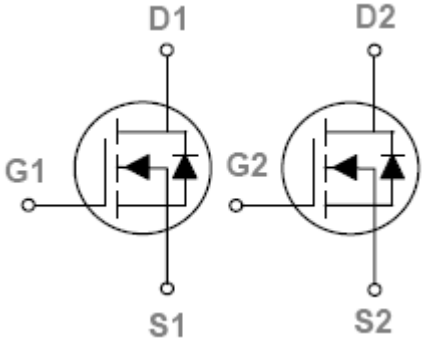

Ordering Information

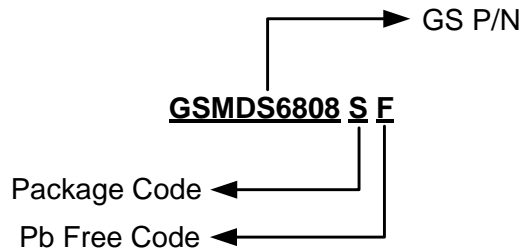

Part Number	Package	Quantity Reel
GSMDS6808SF	SOP-8	3000 PCS

Marking Information

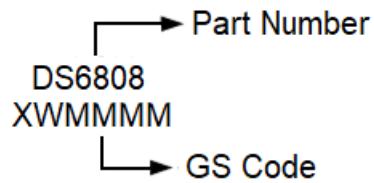

Absolute Maximum Ratings

T_A=25°C Unless otherwise noted

Symbol	Parameter	Typical	Unit
V _{DS}	Drain-Source Voltage	60	V
V _{GS}	Gate-Source Voltage	±20	V
I _D	Continuous Drain Current	T _A =25°C	10
		T _A =100°C	6.3
I _{DM}	Pulsed Drain Current	40	A
EAS	Single Pulse Avalanche Energy	24	mJ
IAS	Single Pulse Avalanche Current	22	A
P _D	Power Dissipation (T _A =25°C)	2.1	W
	Power Dissipation (Derate above 25°C)	0.017	W/°C
T _J	Operating Junction Temperature Range	-50 to +150	°C
T _{STG}	Storage Temperature Range	-50 to +150	°C
R _{θJA}	Thermal Resistance-Junction to Ambient	60	°C/W

Electrical Characteristics

T_A=25°C Unless otherwise noted

Symbol	Parameter	Conditions	Min	Typ	Max	Unit
Static						
V _{(BR)DSS}	Drain-Source Breakdown Voltage	V _{GS} =0V, I _D =250uA	60			V
ΔBV _{DSS} /ΔT _J	BV _{DSS} Temperature Coefficient	Reference to 25°C, I _D =1mA		0.07		V/°C
V _{GS(th)}	Gate Threshold Voltage		1.2	1.8	2.5	V
ΔV _{GS(th)}	V _{GS(th)} Temperature Coefficient	V _{DS} =V _{GS} , I _D =250uA		-4.6		mV/°C
I _{GSS}	Gate Leakage Current	V _{DS} =0V, V _{GS} =±20V			±100	nA
I _{DSS}	Zero Gate Voltage Drain Current	V _{DS} =60V, V _{GS} =0V			1	uA
		V _{DS} =48V, V _{GS} =0V, T _J =125°C			10	
I _S	Continuous Source Current	V _G =V _D =0V, Force Current			10	A
I _{SM}	Pulsed Source Current				40	
R _{DS(on)}	Drain-Source On-Resistance	V _{GS} =10V, I _D =10A		28	34	mΩ
		V _{GS} =4.5V, I _D =6A		34	44	
g _{FS}	Forward Transconductance	V _{DS} =10V, I _D =10A		6		S
V _{SD}	Diode Forward Voltage	V _{GS} =0V, I _S =1A			1	V
t _{rr}	Reverse Recovery Time	V _{GS} =0V, I _S =1A, di/dt=100A/us		14	28	ns
Q _{rr}	Reverse Recovery Charge			10	20	nC
Dynamic						
Q _g	Total Gate Charge	V _{DS} =30V, V _{GS} =10V, I _D =10A		16.6	24	nC
Q _{gs}	Gate-Source Charge			2.2	4.4	
Q _{gd}	Gate-Drain Charge			3.9	8	
C _{iss}	Input Capacitance	V _{DS} =30V, V _{GS} =0V, f=1MHz		1180	1720	pF
C _{oss}	Output Capacitance			68	100	
C _{rss}	Reverse Transfer Capacitance			45	70	
t _{d(on)}	Turn-On Time	V _{DD} =30V, I _D =1A, V _{GS} =10V, R _G =6Ω		4.6	9	ns
t _r				14.8	28	
t _{d(off)}	Turn-Off Time			27.2	52	
t _f				7.8	15	
R _g	Gate Resistance	V _{DS} =0V, V _{GS} =0V, f=1MHz		2.1	4.2	Ω

Typical Performance Characteristics

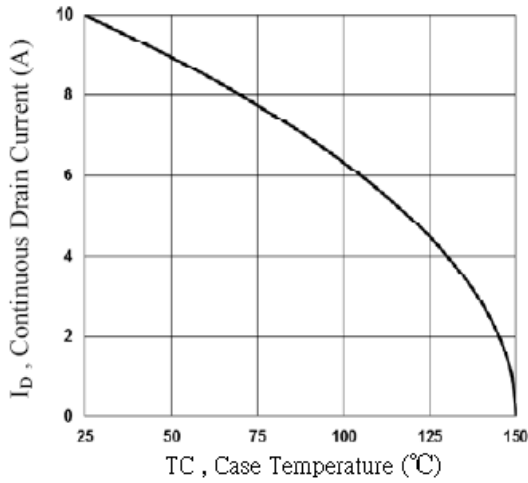

Fig.1 Continuous Drain Current vs. T_c

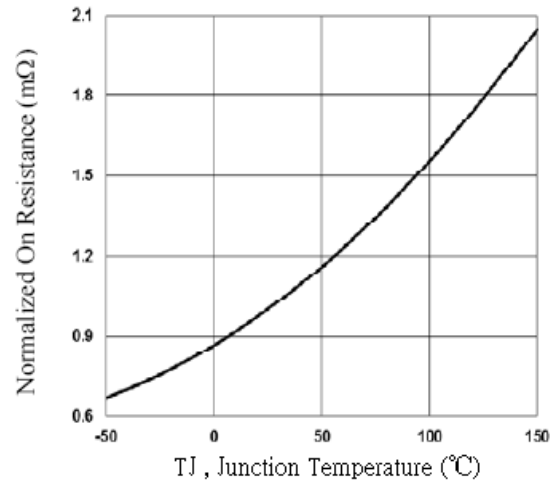

Fig.2 Normalized $R_{DS(on)}$ vs. T_j

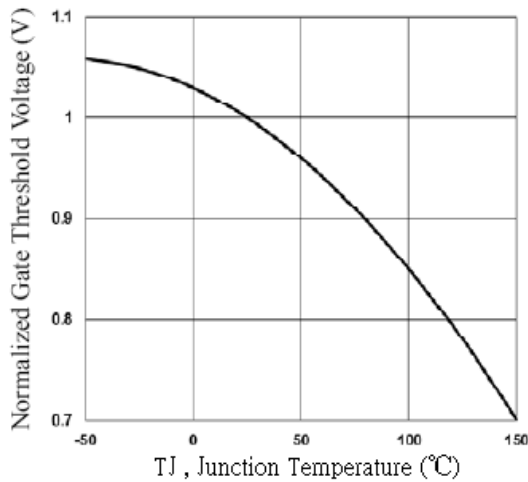

Fig.3 Normalized V_{th} vs. T_j

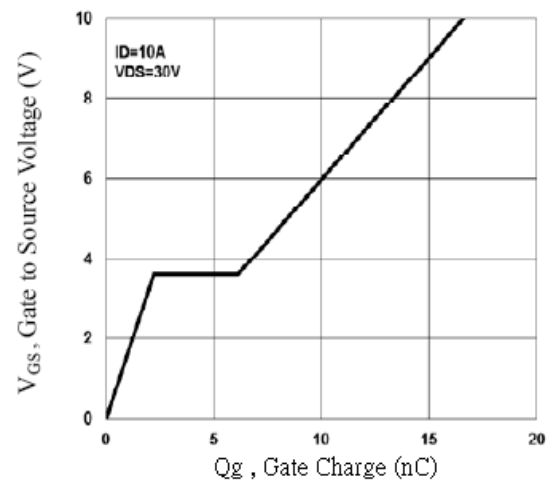

Fig.4 Gate Charge Waveform

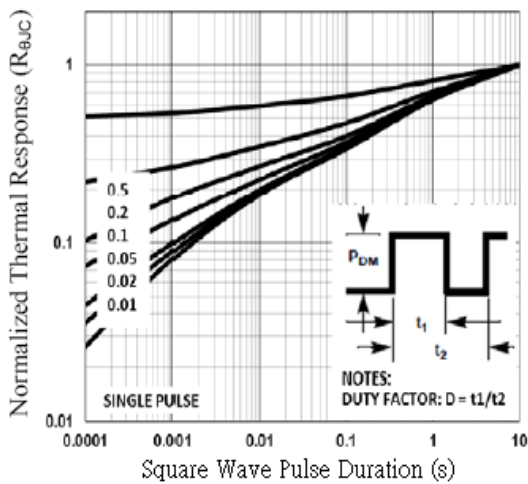

Fig.5 Normalized Transient Impedance

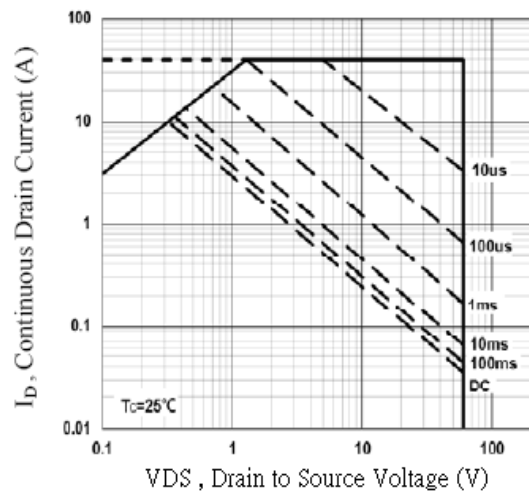
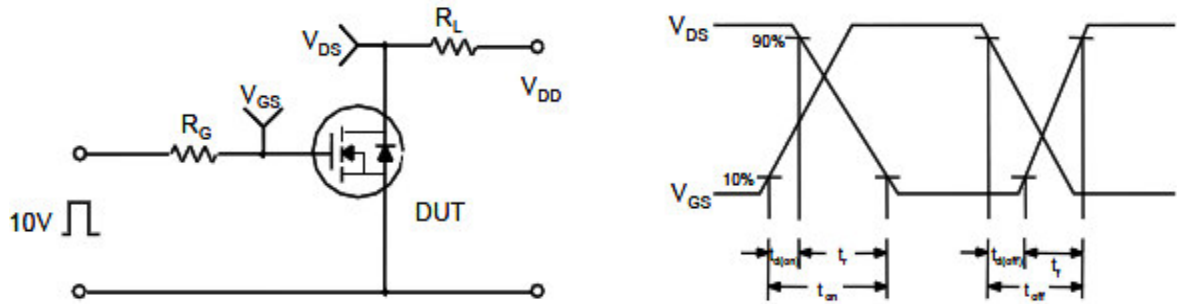

Fig.6 Maximum Safe Operation Area

Typical Performance Characteristics (Continue)

Resistive Switching Test Circuit & Waveforms



Unclamped Inductive Switching Test Circuit & Waveforms

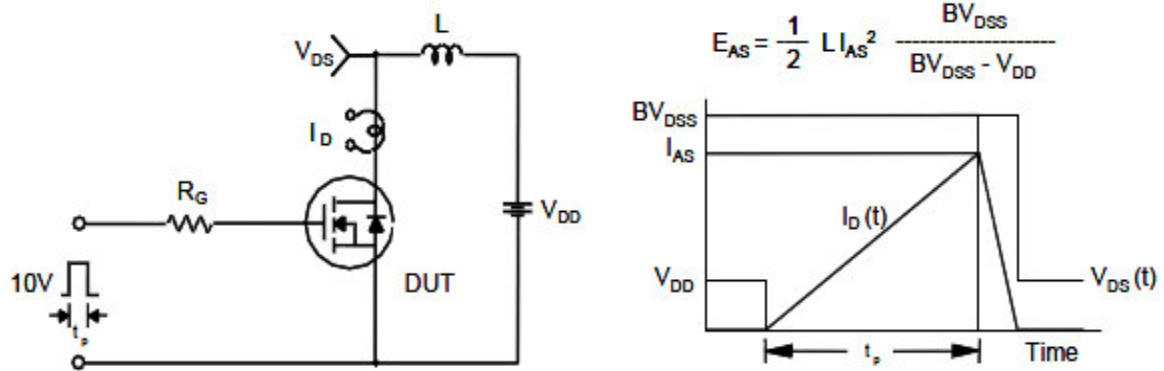

Package Dimension

SOP-8

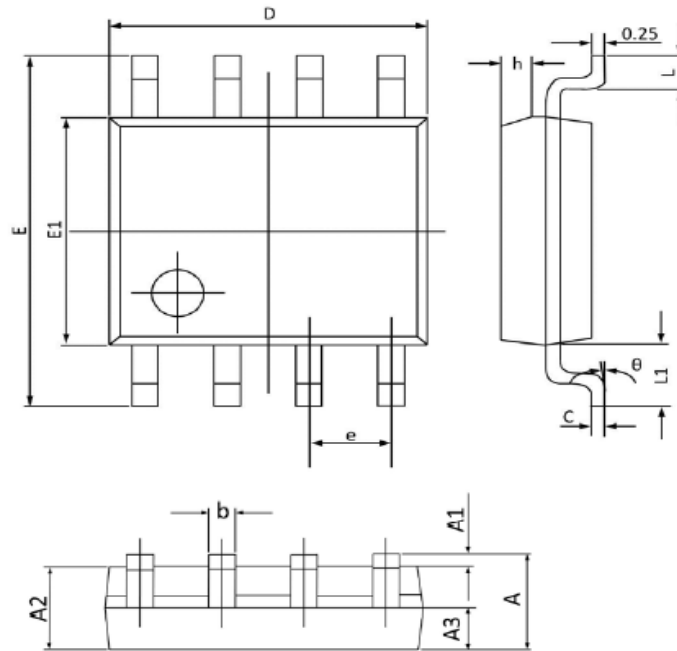





Dimensions



Symbol	Millimeters		Inches	
	Min	Max	Min	Max
A	1.350	1.750	0.053	0.068
A1	0.100	0.250	0.004	0.009
A2	1.300	1.500	0.052	0.059
A3	0.600	0.700	0.024	0.027
b	0.390	0.480	0.016	0.018
c	0.210	0.260	0.009	0.010
D	4.700	5.100	0.186	0.200
E	5.800	6.200	0.229	0.244
E1	3.700	4.100	0.146	0.161
e	1.270 (BSC)		0.050 (BSC)	
h	0.250	0.500	0.010	0.019
L	0.500	0.800	0.019	0.031
L1	1.050 (BSC)		0.041 (BSC)	
θ	0°	8°	0°	8°

NOTICE

Information furnished is believed to be accurate and reliable. However Globaltech Semiconductor assumes no responsibility for the consequences of use of such information nor for any infringement of patents or other rights of third parties, which may result from its use. No license is granted by implication or otherwise under any patent or patent rights of Globaltech Semiconductor. Specifications mentioned in this publication are subject to change without notice. This publication supersedes and replaces all information without express written approval of Globaltech Semiconductor.

CONTACT US

GS Headquarter	
	4F.,No.43-1,Lane11,Sec.6,Minquan E.Rd Neihu District Taipei City 114, Taiwan (R.O.C)
	886-2-2657-9980
	886-2-2657-3630
	sales_twn@gs-power.com

RD Division	
	824 Bolton Drive Milpitas. CA. 95035
	1-408-457-0587