

GSM4911P

40V P-Channel MOSFETs

Product Description

These P-Channel enhancement mode power field effect transistors are using trench DMOS technology. This advanced technology has been especially tailored to minimize on-state resistance, provide superior switching performance, and withstand high energy pulse in the avalanche and commutation mode.

These devices are well suited for high efficiency fast switching applications.

Features

- -40V, -2.9A, $R_{DS(ON)}=68m\Omega@V_{GS}=-10V$
- Fast switching
- Suit for -4.5V Gate Drive Applications
- Green Device Available

Applications

- POL Applications
- Load Switch
- LED Application

Packages & Pin Assignments

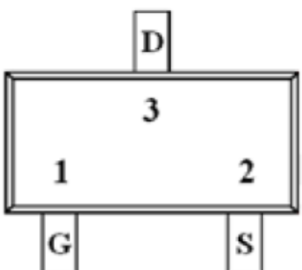
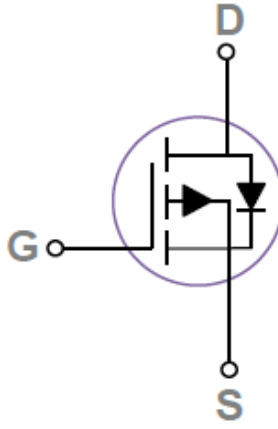
GSM4911PJZF (SOT-23)	
 <p>Top Views</p>	
	
Pin	Description
1	Gate
2	Source
3	Drain

Ordering Information

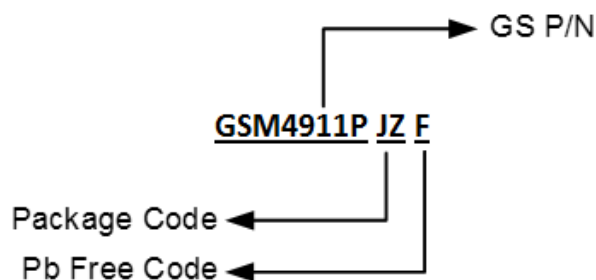

Part Number	Package	Quantity
GSM4911PJZF	SOT-23	3000pcs

Marking Information

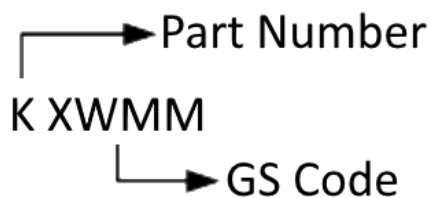

Part Number	Package	Part Marking
GSM4911PJZF	SOT-23	KXWMM

Absolute Maximum Ratings (T_C=25°C Unless otherwise noted)

Symbol	Parameter	Typical	Unit
V _{DS}	Drain-Source Voltage	-40	V
V _{GS}	Gate-Source Voltage	±20	V
I _D	Continuous Drain Current	T _A =25°C	-2.9
		T _A =100°C	-2.32
I _{DM}	Pulsed Drain Current ¹	-11.6	A
P _D	Power Dissipation (T _A =25°C)	1	W
	Power Dissipation (Derate above 25°C)	8	mW/°C
T _J	Operating Junction Temperature Range	-55 to +150	°C
T _{STG}	Storage Temperature Range	-55 to +150	°C
Symbol	Parameter	Max	Unit
R _{θJA}	Thermal Resistance-Junction to Ambient	125	°C/W

Electrical Characteristics (T_J=25°C Unless otherwise noted)

Symbol	Parameter	Conditions	Min	Typ	Max	Unit
Static						
V _{(BR)DSS}	Drain-Source Breakdown Voltage	V _{GS} =0V, I _D =-250uA	-40			V
V _{GS(th)}	Gate Threshold Voltage	V _{DS} =V _{GS} , I _D =-250uA	-1.0	-1.65	-2.5	V
I _{GSS}	Gate Leakage Current	V _{DS} =0V, V _{GS} =±20V			±100	nA
I _{DSS}	Zero Gate Voltage Drain Current	V _{DS} =-40V, V _{GS} =0V, T _J =25°C			-1	uA
		V _{DS} =-32V, V _{GS} =0V, T _J =125°C			-10	
I _S	Continuous Source Current	V _G =V _D =0V, Force Current			-2.9	A
I _{SM}	Pulsed Source Current				-5.8	
R _{DS(on)}	Drain-Source On-Resistance	V _{GS} =-10V, I _D =-2A		55	68	mΩ
		V _{GS} =-4.5V, I _D =-1A		75	100	
g _{FS}	Forward Transconductance	V _{DS} =-10V, I _D =-1A		3		S
V _{SD}	Diode Forward Voltage	V _{GS} =0V, I _S =-1A, T _J =25°C			-1	V
Dynamic						
Q _g	Total Gate Charge ^{2,3}	V _{DS} =-32V, V _{GS} =-10V, I _D =-2A		6.4	13	nC
Q _{gs}	Gate-Source Charge ^{2,3}			0.5	2	
Q _{gd}	Gate-Drain Charge ^{2,3}			2.7	6	
C _{iss}	Input Capacitance	V _{DS} =-25V, V _{GS} =0V, f=1MHz		600	1200	pF
C _{oss}	Output Capacitance			60	120	
C _{rss}	Reverse Transfer Capacitance			43	80	
t _{d(on)}	Turn-On Time ^{2,3}	V _{DD} =-20V, I _D =-1A, V _{GS} =-10V, R _G =6Ω		12	24	ns
t _r	Rise Time ^{2,3}			9	20	
t _{d(off)}	Turn-Off Time ^{2,3}			45	90	
t _f	Fall Time ^{2,3}			5	10	

Note :

1. Repetitive Rating : Pulsed width limited by maximum junction temperature.
2. The data tested by pulsed , pulse width ≤ 300us , duty cycle ≤ 2%.
3. Essentially independent of operating temperature.

Typical Performance Characteristics

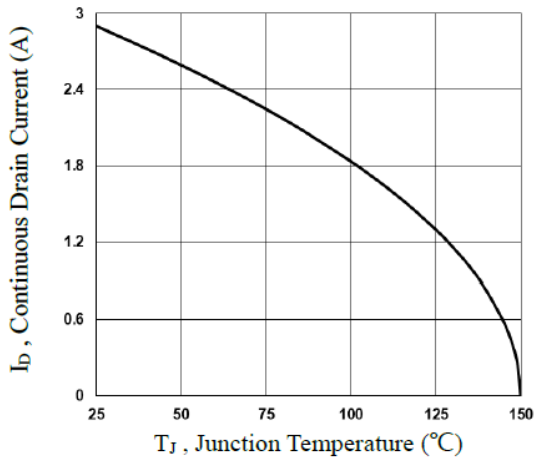

Fig.1 Continuous Drain Current vs. T_J

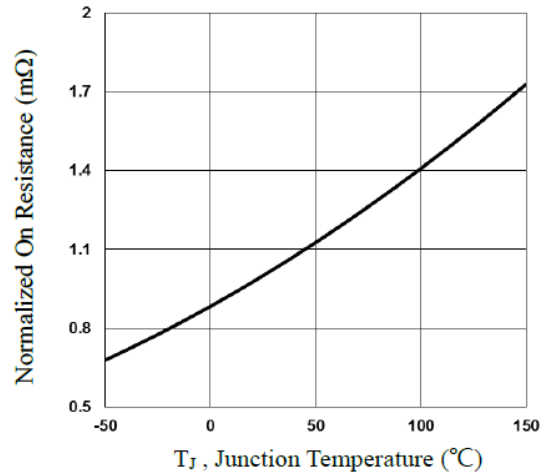

Fig.2 Normalized $R_{DS(on)}$ vs. T_J

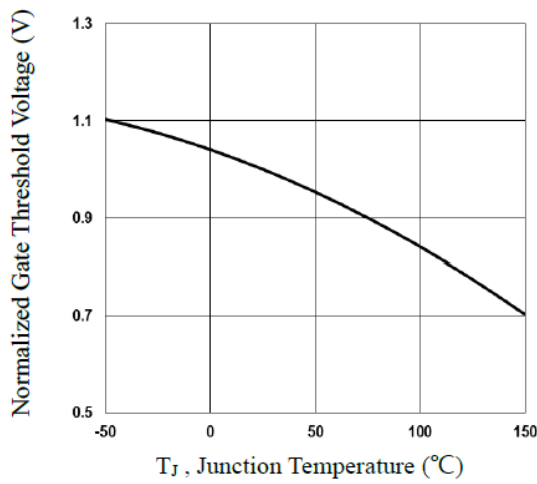

Fig.3 Normalized V_{th} vs. T_J

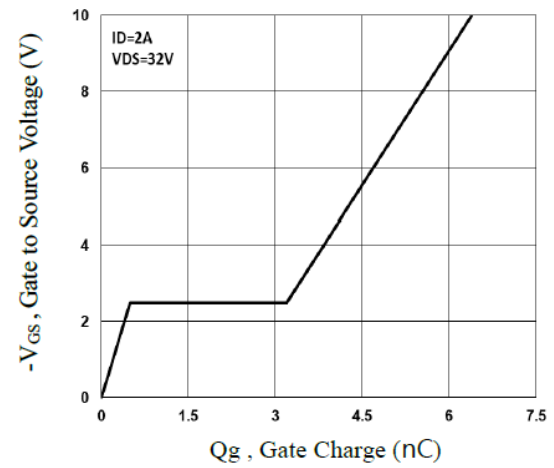

Fig.4 Gate Charge Waveform

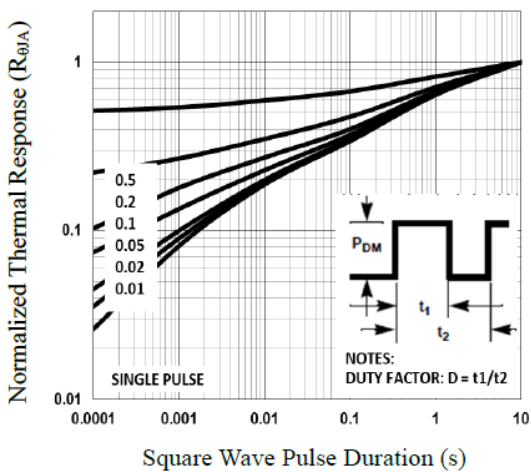

Fig.5 Normalized Transient Impedance

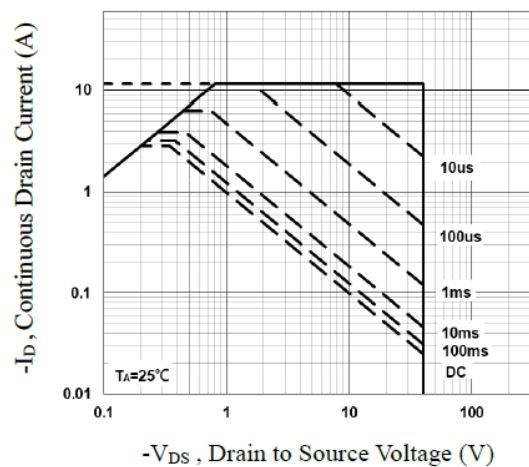

Fig.6 Maximum Safe Operation Area

Typical Performance Characteristics (Continue)

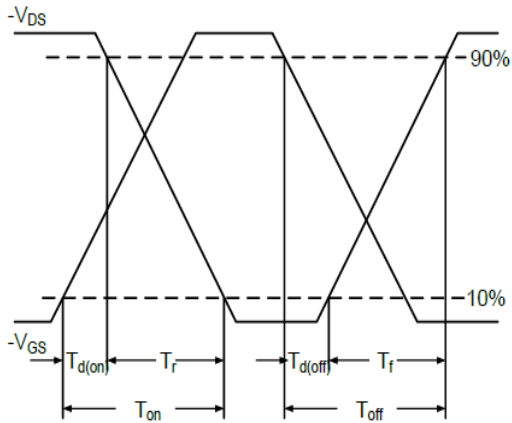

Fig.7 Switching Time Waveform

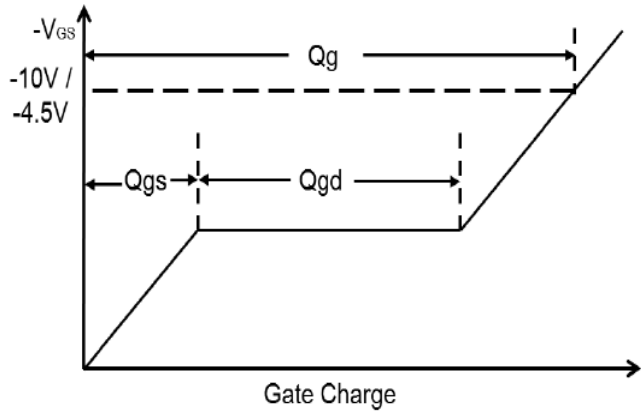
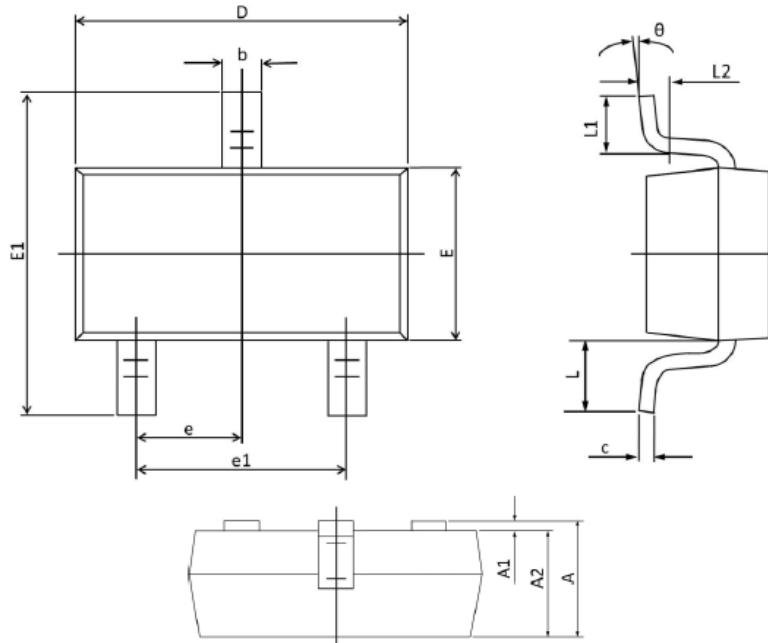

Fig.8 Gate Charge Waveform

Package Dimension

SOT-23







Dimensions



Symbol	Millimeters		Inches	
	Min	Max	Min	Max
A	0.900	1.150	0.035	0.045
A1	0.000	0.100	0.000	0.004
A2	0.900	1.050	0.035	0.041
b	0.300	0.500	0.012	0.020
c	0.080	0.150	0.003	0.006
D	2.800	3.000	0.110	0.118
E	1.200	1.400	0.047	0.055
E1	2.250	2.550	0.089	0.100
e	0.950 TYP		0.037 TYP	
e1	1.800	2.000	0.071	0.079
L	0.550 REF		0.022 REF	
L1	0.300	0.500	0.012	0.020
L2	0.250 TYP		0.010 TYP	
θ	0°	8°	0°	8°

NOTICE

Information furnished is believed to be accurate and reliable. However Globaltech Semiconductor assumes no responsibility for the consequences of use of such information nor for any infringement of patents or other rights of third parties, which may result from its use. No license is granted by implication or otherwise under any patent or patent rights of Globaltech Semiconductor. Specifications mentioned in this publication are subject to change without notice. This publication supersedes and replaces all information without express written approval of Globaltech Semiconductor.

CONTACT US

GS Headquarter	
	4F.,No.43-1,Lane11,Sec.6,Minquan E.Rd Neihu District Taipei City 114, Taiwan (R.O.C)
	886-2-2657-9980
	886-2-2657-3630
	sales_twn@gs-power.com

RD Division	
	824 Bolton Drive Milpitas. CA. 95035
	1-408-457-0587