

GSM4910D

40V N-Channel MOSFET

Product Description

These N-Channel enhancement mode power field effect transistors are using trench DMOS technology. This advanced technology has been especially tailored to minimize on-state resistance, provide superior switching performance, and withstand high energy pulse in the avalanche and commutation mode.

These devices are well suited for high efficiency fast switching applications.

Features

- 40V, 34A, $R_{DS(ON)} = 17\text{m}\Omega @ V_{GS} = 10\text{V}$
- Improved dv/dt capability
- Fast switching
- Green Device Available

Applications

- Notebook
- Load Switch
- LED application
- Hand-Held Device

Packages & Pin Assignments

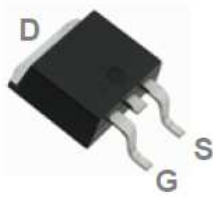
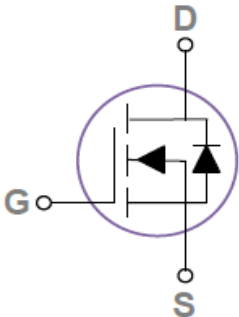
GSM4910DF (TO-252-2L)	
 Top View	
Description	
Gate	
Drain	
Source	

Ordering Information

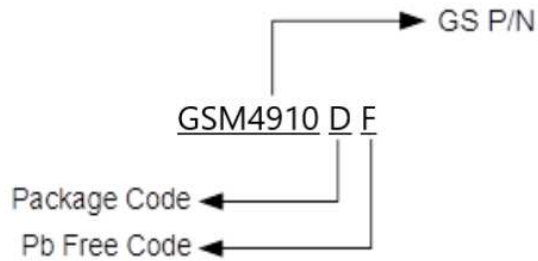

Part Number	Package	Quantity Reel
GSM4910DF	TO-252-2L	2500 PCS

Marking Information

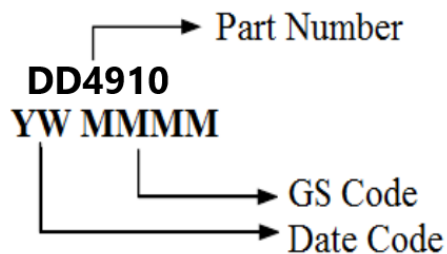

Absolute Maximum Ratings

T_c=25°C Unless otherwise noted

Symbol	Parameter	Typical	Unit
V _{DS}	Drain-Source Voltage	40	V
V _{GS}	Gate-Source Voltage	±20	V
I _D	Continuous Drain Current	T _c =25°C	34
		T _c =100°C	21.5
I _{DM}	Pulsed Drain Current ¹	136	A
P _D	Power Dissipation (T _c =25°C)	33	W
	Power Dissipation (Derate above 25°C)	0.26	W/°C
T _J	Operating Junction Temperature Range	-55 to +150	°C
T _{STG}	Storage Temperature Range	-55 to +150	°C
R _{θJA}	Thermal Resistance-Junction to Ambient	62	°C/W
R _{θJC}	Thermal Resistance-Junction to Case	3.84	°C/W

Electrical Characteristics

T_J=25°C Unless otherwise noted

Symbol	Parameter	Conditions	Min	Typ	Max	Unit
Static						
V _{(BR)DSS}	Drain-Source Breakdown Voltage	V _{GS} =0V, I _D =250uA	40			V
ΔV _{DSS} /ΔT _J	V _{DSS} Temperature Coefficient	Reference to 25°C , I _D =1mA		0.034		V/°C
V _{GS(th)}	Gate Threshold Voltage	V _{DS} =V _{GS} , I _D =250uA	1.2	1.6	2.5	V
ΔV _{GS(th)}	V _{GS(th)} Temperature Coefficient			-4.3		mV/°C
I _{GSS}	Gate-Source Leakage Current	V _{DS} =0V, V _{GS} =±20V			±100	nA
I _{DSS}	Drain-Source Leakage Current	V _{DS} =40V, V _{GS} =0V, T _J =25°C			1	uA
		V _{DS} =32V, V _{GS} =0V, T _J =85°C			10	
I _S	Continuous Source Current	V _G =V _D =0V, Force Current			34	A
I _{SM}	Pulsed Source Current				68	
R _{DS(on)}	Drain-Source On-Resistance	V _{GS} =10V, I _D =6A		14	17	mΩ
		V _{GS} =4.5V, I _D =4A		18	23	
g _{FS}	Forward Transconductance	V _{DS} =10V, I _D =3A		6		S
V _{SD}	Diode Forward Voltage	V _{GS} =0V, I _S =1A, T _J =25°C			1	V
Dynamic						
Q _g	Total Gate Charge ^{2,3}	V _{DS} =32V, V _{GS} =10V, I _D =6A		11.8	23	nC
Q _{gs}	Gate-Source Charge ^{2,3}			1.7	3.4	
Q _{gd}	Gate-Drain Charge ^{2,3}			4	8	
C _{iss}	Input Capacitance	V _{DS} =20V, V _{GS} =0V, F=1MHz		722	1440	pF
C _{oss}	Output Capacitance			83	166	
C _{rss}	Reverse Transfer Capacitance			61	122	
t _{d(on)}	Turn-On Time ^{2,3}	V _{DD} =20V, I _D =1A, V _{GS} =10V, R _G =3.3Ω		5	10	ns
t _r				8	16	
t _{d(off)}	Turn-Off Time ^{2,3}			17	34	
t _f				5	10	
R _g	Gate Resistance		V _{DS} =0V, V _{GS} =0V, F=1MHz		2.1	

Note :

1. Repetitive Rating : Pulsed width limited by maximum junction temperature.
2. The data tested by pulsed , pulse width ≤ 300us , duty cycle ≤ 2%.
3. Essentially independent of operating temperature.

Typical Performance Characteristics

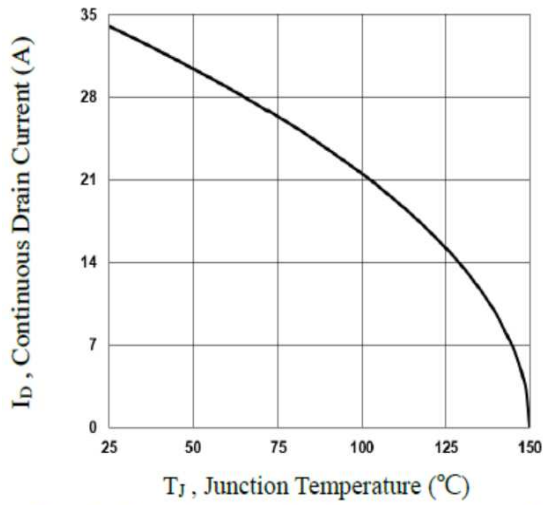

Fig.1 Continuous Drain Current vs. T_J

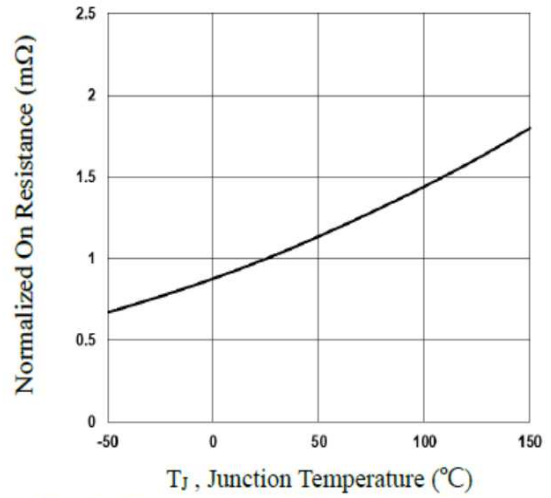

Fig.2 Normalized $R_{DS(on)}$ vs. T_J

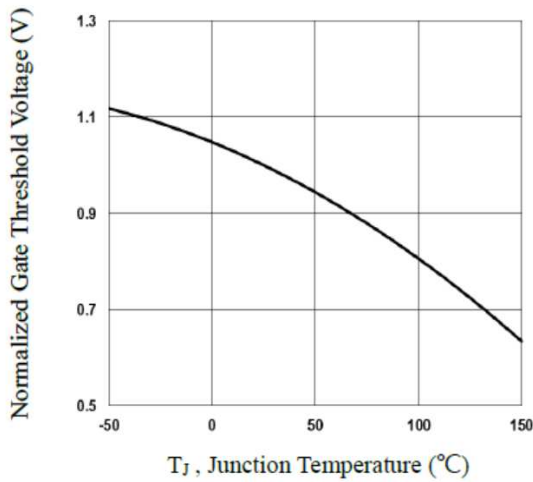

Fig.3 Normalized V_{th} vs. T_J

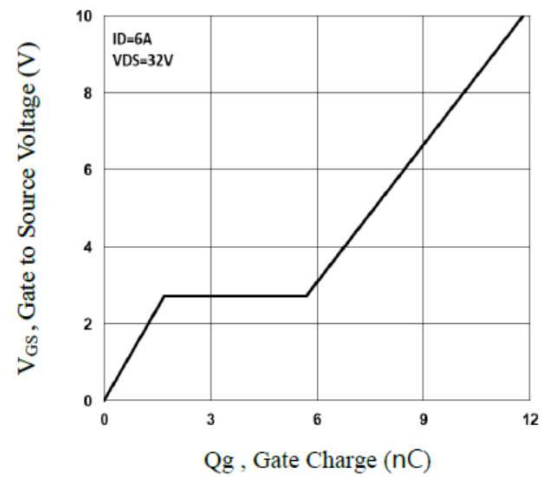

Fig.4 Gate Charge Waveform

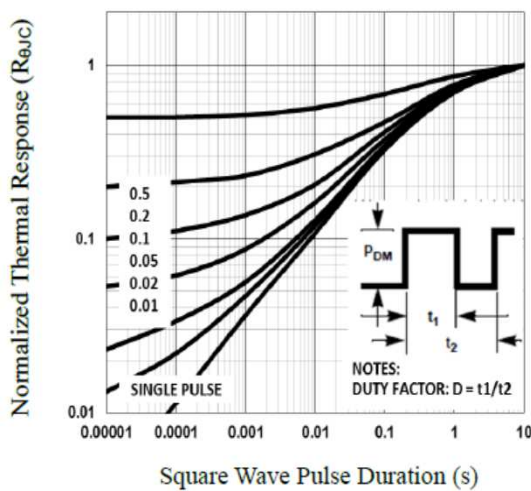

Fig.5 Normalized Transient Impedance

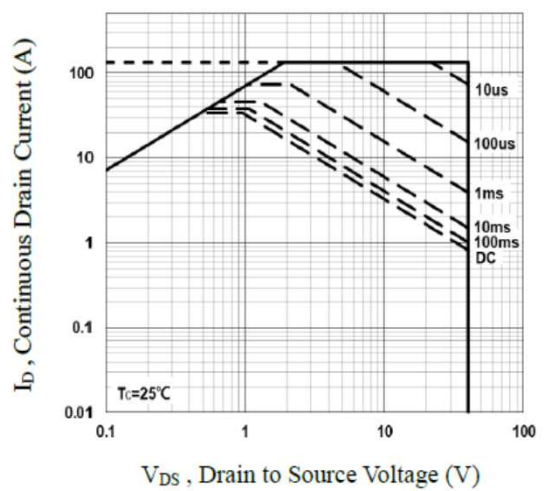

Fig.6 Maximum Safe Operation Area

Typical Performance Characteristics (continue)

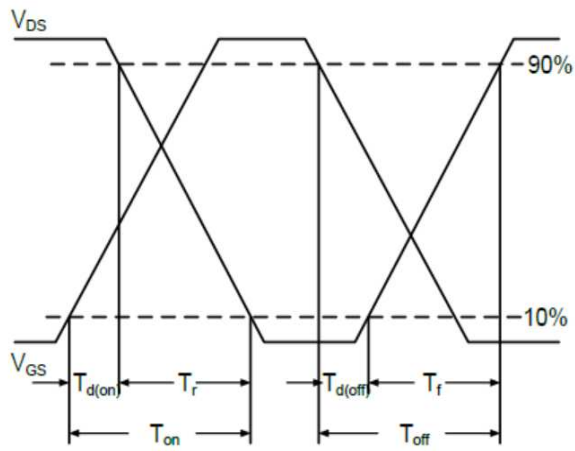

Fig.7 Switching Time Waveform

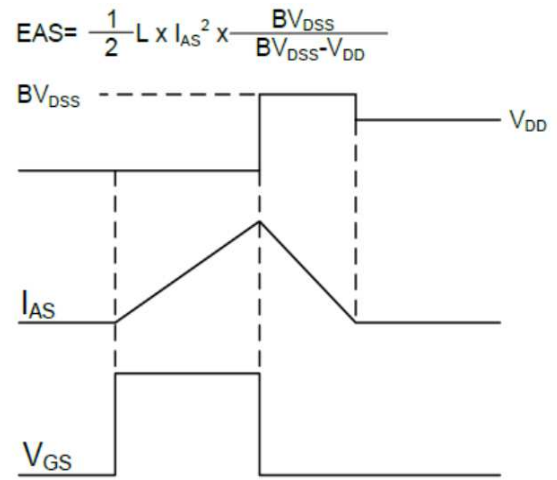
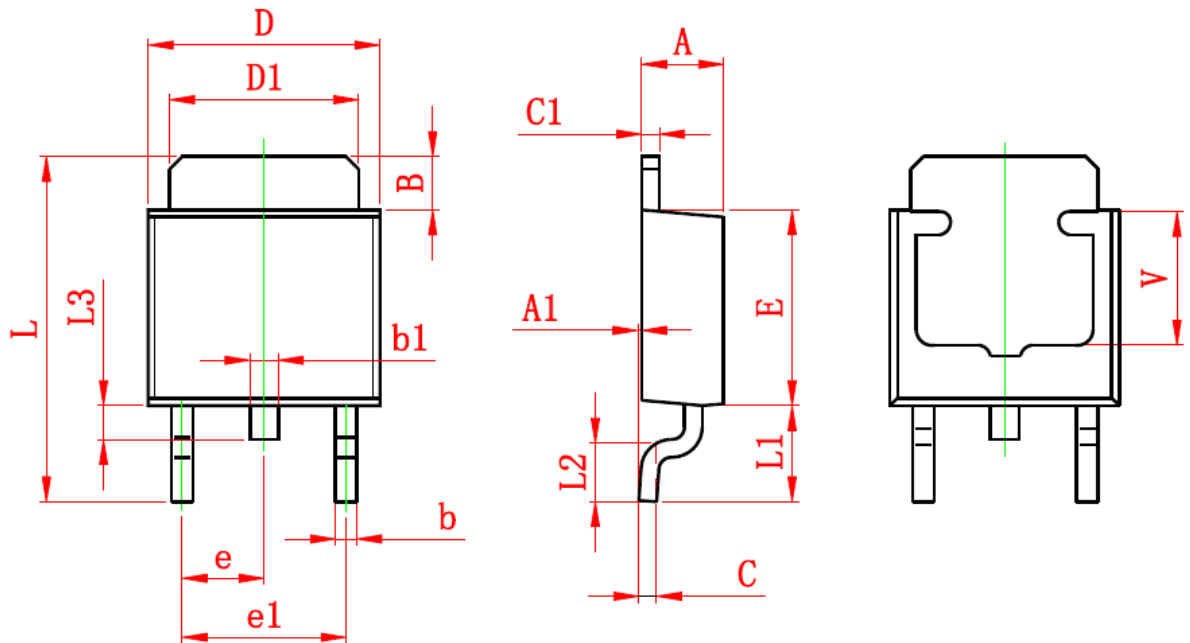

Fig.8 EAS Waveform

Package Dimension

TO-252-2L









Dimensions				
SYMBOL	Millimeters		Inches	
	MIN	MAX	MIN	MAX
A	2.200	2.400	0.087	0.094
A1	0.000	0.127	0.000	0.005
B	1.350	1.650	0.053	0.065
b	0.500	0.700	0.020	0.028
b1	0.700	0.900	0.028	0.035
C	0.430	0.580	0.017	0.023
C1	0.430	0.580	0.017	0.023
D	6.350	6.650	0.250	0.262
D1	5.200	5.400	0.205	0.213
E	5.400	5.700	0.213	0.224
e	2.300 TYP.		0.091 TYP.	
e1	4.500	4.700	0.177	0.185
L	9.500	9.900	0.374	0.390
L1	2.550	2.900	0.100	0.114
L2	1.400	1.780	0.055	0.070
L3	0.600	0.900	0.024	0.035
V	3.800 REF.		0.150 REF.	

NOTICE

Information furnished is believed to be accurate and reliable. However Globaltech Semiconductor assumes no responsibility for the consequences of use of such information nor for any infringement of patents or other rights of third parties, which may result from its use. No license is granted by implication or otherwise under any patent or patent rights of Globaltech Semiconductor. Specifications mentioned in this publication are subject to change without notice. This publication supersedes and replaces all information without express written approval of Globaltech Semiconductor.

CONTACT US

GS Headquarter	
	4F.,No.43-1,Lane11,Sec.6,Minquan E.Rd Neihu District Taipei City 114, Taiwan (R.O.C)
	886-2-2657-9980
	886-2-2657-3630
	sales_twn@gs-power.com

RD Division	
	824 Bolton Drive Milpitas. CA. 95035
	1-408-457-0587