

GSM3117SF

30V P-Channel Enhancement Mode MOSFET

Product Description

The P-Channel enhancement mode power field effect transistor is using trench DMOS technology. This advanced technology has been especially tailored to minimize on-state resistance, provide superior switching performance, and withstand high energy pulse in the avalanche and commutation mode.

This device is well suited for high efficiency fast switching applications.

Features

- $R_{DS(ON)}=18m\Omega@V_{GS}=-10V$
- $R_{DS(ON)}=26m\Omega@V_{GS}=-4.5V$
- Fast switching
- Suit for -4.5V Gate Drive Applications
- Green Device Available
- SOP-8 package design

Applications

- MB / VGA / Vcore
- POL Applications
- Load Switch
- LED Application

Packages & Pin Assignments

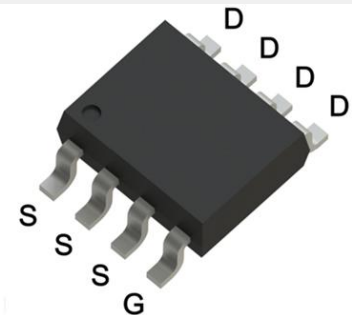
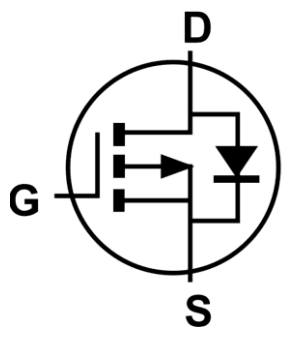
GSM3117SF (SOP-8)		Equivalent Circuit
		
Pin	Description	
1	Source	
2	Source	
3	Source	
4	Gate	
5	Drain	
6	Drain	
7	Drain	
8	Drain	

Ordering and Marking Information

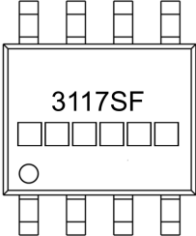
Ordering Information			
Part Number	Package	Part Marking	Quantity / Reel
GSM3117SF	SOP-8	3117SF □□□□□□	4,000 PCS
GSM3117 1 2			
- Product Code: GSM3117		- Package Code: 1 is S for SOP-8	
		- Green Level: 2 is F for RoHS Compliant and Halogen Free	
Marking Information			
		- Product Code: 3117SF	
		- GS Code: □□□□□□	

Absolute Maximum Ratings

T_A=25°C, unless otherwise specified

Symbol	Parameter	Value	Unit
V _{DSS}	Drain-Source Voltage	-30	V
V _{GSS}	Gate-Source Voltage	±25	V
I _D	Continuous Drain Current	T _C =25°C	-13.8
		T _C =70°C	-11.1
		T _A =25°C	-7.8
		T _A =70°C	-6.2
I _{DM}	Pulsed Drain Current	-50	A
P _D	Power Dissipation	T _C =25°C	5.3
		T _C =70°C	3.4
		T _A =25°C	1.7
		T _A =70°C	1.1
T _J	Operating Junction Temperature Range	-55 to +150	°C
T _{STG}	Storage Temperature Range	-55 to +150	°C
R _{θJA}	Thermal Resistance, Junction to Ambient	75	°C/W
R _{θJC}	Thermal Resistance, Junction to Case	24	°C/W

Electrical Characteristics

T_A=25°C, unless otherwise specified

Symbol	Parameter	Test Conditions	Min.	Typ.	Max.	Unit
Static characteristics						
B _V DSS	Drain-Source Breakdown Voltage	V _{GS} =0V, I _D =-250uA	-30	-	-	V
V _{GS(th)}	Gate Threshold Voltage	V _{DS} =V _{GS} , I _D =-250uA	-1.2	-	-2.5	V
I _{GSS}	Gate Leakage Current	V _{DS} =0V, V _{GS} =±25V	-	-	±100	nA
I _{DSS}	Drain-Source Leakage Current	V _{DS} =-30V, V _{GS} =0V	-	-	-1	uA
V _{SD}	Diode Forward Voltage ³	V _{GS} =0V, I _S =-1A	-	-	-1	V
R _{DS(ON)}	Drain-Source On-Resistance	V _{GS} =-10V, I _D =-10A	-	12.3	18	mΩ
		V _{GS} =-4.5V, I _D =-6A	-	19.4	26	
Gate charge characteristics						
Q _g	Total Gate Charge	V _{DD} =-15V, V _{GS} =-4.5V, I _D =-15A	-	22	-	nC
Q _{gs}	Gate-Source Charge		-	8.7	-	
Q _{gd}	Gate-Drain Charge		-	7.2	-	
Dynamic characteristics						
C _{iss}	Input Capacitance	V _{DS} =-15V, V _{GS} =0V, f=1.0MHz	-	2215	-	pF
C _{oss}	Output Capacitance		-	310	-	
C _{rss}	Reverse Transfer Capacitance		-	237	-	
t _{d(on)}	Turn-On Time	V _{DD} =-15V, V _{GS} =-10V, R _g =3.3Ω, I _D =-15A	-	8	-	ns
t _r	Rise Time		-	73.7	-	
t _{d(off)}	Turn-Off Time		-	61.8	-	
t _f	Fall Time		-	24.4	-	

Typical Performance Characteristics

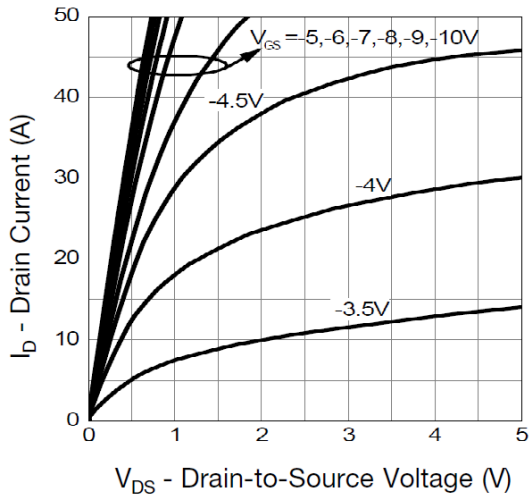

Figure 1. Output Characteristics

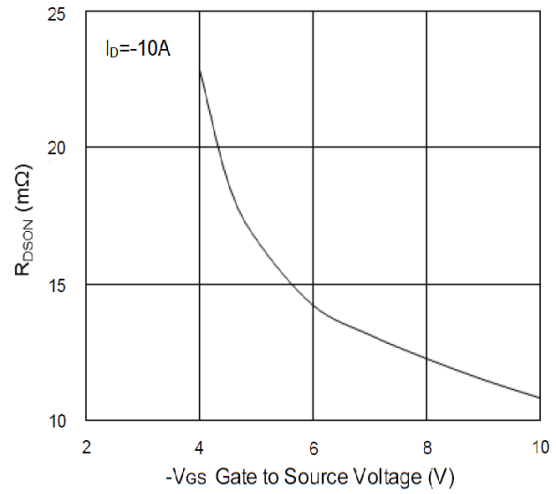

Figure 2. On-Resistance Variation with V_{GS}

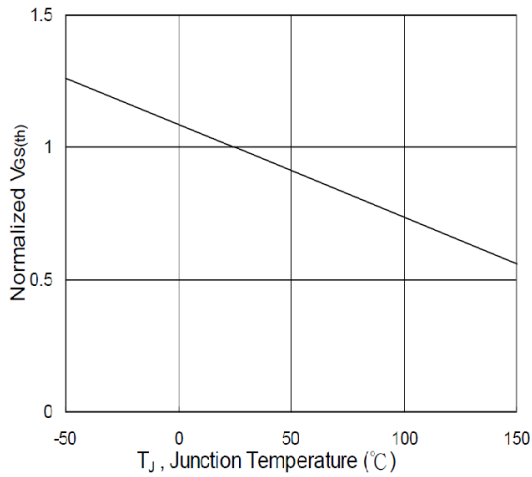

Figure 3. Normalized $V_{GS(th)}$ vs. T_J

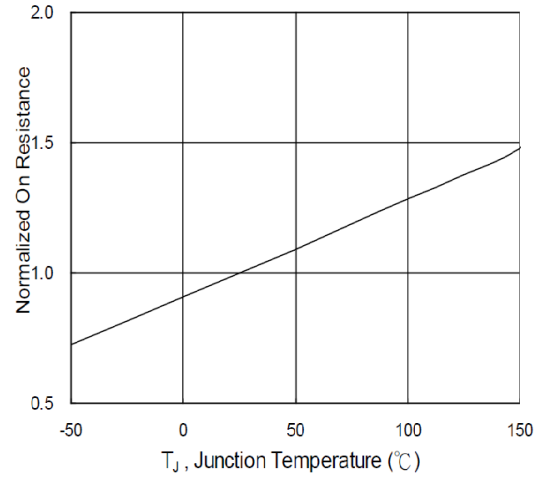

Figure 4. Normalized $R_{DS(on)}$ vs. T_J

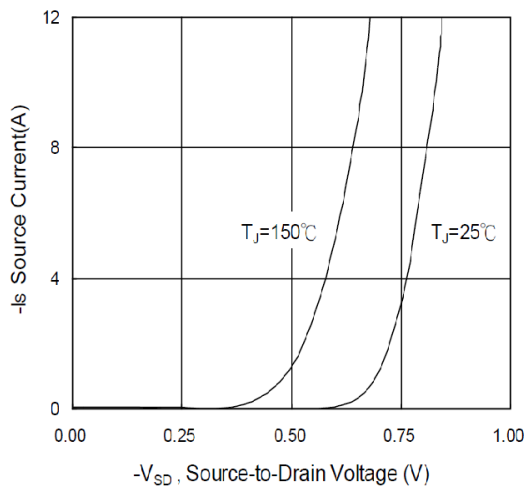

Figure 5. Diode Forward Voltage vs. Current

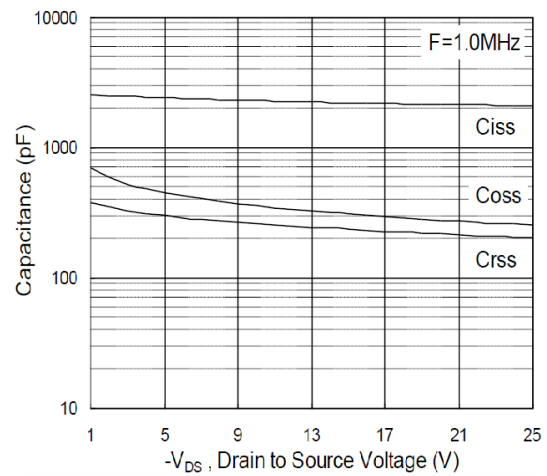

Figure 6. Capacitance

Typical Performance Characteristics

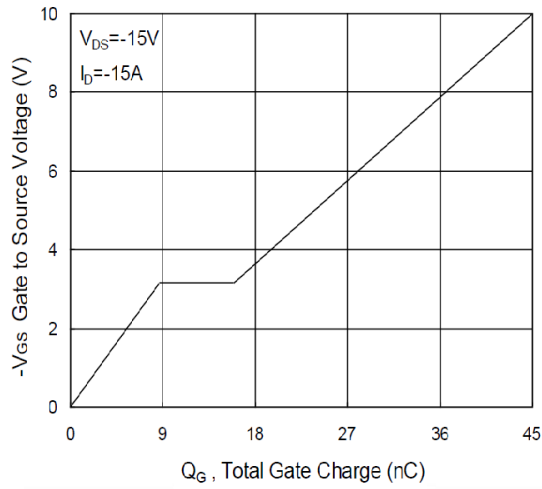

Figure 7. Gate Charge Waveform

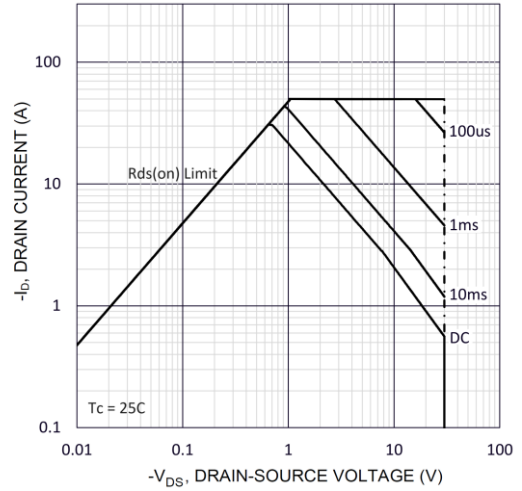

Figure 8. Maximum Safe Operating Area

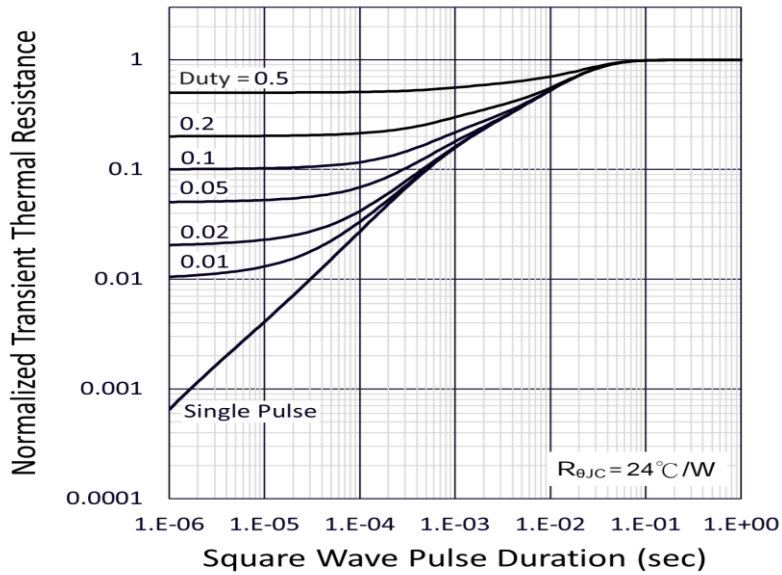
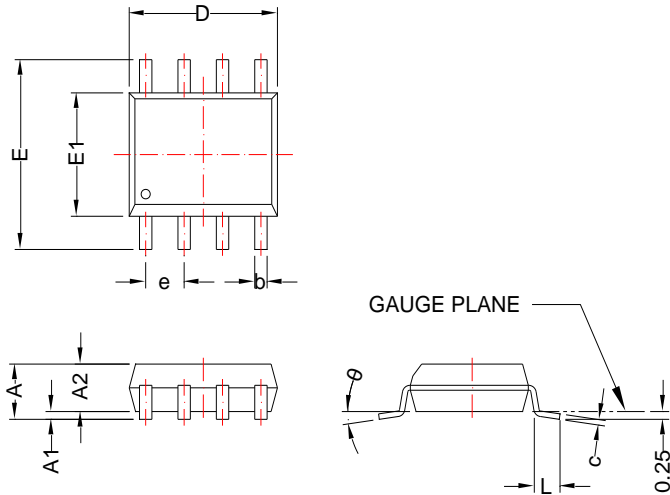

Figure 9. Normalized Transient Thermal Resistance

SOP-8

Package Dimension



Recommended Land Pattern

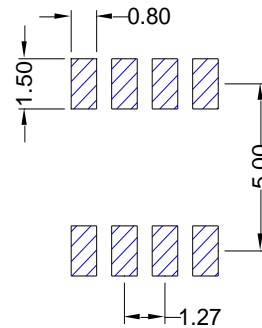





Dimensions				
Symbol	Millimeters		Inches	
	MIN	MAX	MIN	MAX
A	-	1.75	-	0.069
A1	0.10	0.25	0.004	0.010
A2	1.25	-	0.049	-
b	0.31	0.51	0.012	0.020
c	0.10	0.25	0.004	0.010
D	4.70	5.10	0.185	0.201
E	5.80	6.20	0.228	0.244
E1	3.80	4.00	0.150	0.157
e	1.27 BSC		0.050 BSC	
L	0.4	1.27	0.016	0.050
θ	0°	8°	0°	8°



NOTE:
Dimensions are exclusive of Burrs, Mold Flash & Tie Bar extrusions

NOTICE

- Globaltech Semiconductor assumes no responsibility for equipment failures that result from using products at values that exceed, even momentarily, rated values (such as maximum ratings, operating condition ranges, or other parameters) listed in products specifications of any and all Globaltech Semiconductor products described or contained herein. Globaltech Semiconductor products are not designed for use in life support appliances, devices or systems where malfunction of these products can be reasonably expected to result in personal injury. Reproduction in whole or in part is prohibited without the prior written consent of the copyright owner.
- Applications shown on the herein document are examples of standard use and operation. Customers are responsible in comprehending the suitable use in particular applications. Globaltech Semiconductor makes no representation or warranty that such applications will be suitable for the specified use without further testing or modification.
- The information furnished is believed to be accurate and reliable. However, Globaltech Semiconductor assumes no responsibility for the consequences of use of such information nor for any infringement of patents or other rights of third parties, which may result from its use. No license is granted by implication or otherwise under any patent or patent rights of Globaltech Semiconductor. Specifications mentioned in this publication are subject to change without notice. This publication supersedes and replaces all information without express written approval of Globaltech Semiconductor.

CONTACT US

GS Headquarter	
	4F.,No.43-1,Lane11,Sec.6,Minquan E.Rd Neihu District Taipei City 114, Taiwan (R.O.C)
	886-2-2657-9980
	886-2-2657-3630
	sales_twn@gs-power.com

RD Division	
	824 Bolton Drive Milpitas. CA. 95035
	1-408-457-0587