

GS5452

18V, 2A, Synchronous Step-Down DC/DC Converter

Product Description

The GS5452 is a wide input range, high-efficiency and high frequency DC-to-DC step-down switching regulator, capable of delivering up to 2A of output current. It adopts an Adaptive COT control scheme that enables very fast transient response and provides a very smooth transition when the output varies from light load to heavy load. During light load, GS5452 goes into a PFM mode that saves switching loss achieving high efficiency. The adaptive COT control also maintains a constant switching frequency across line and load. An OVP function protects the IC itself and its downstream system against input voltage surges. With this OVP function, the IC can stand off input voltage as high as 25V, making it an ideal solution for industrial applications such as LCD TV, Set Top Box, Portable TV, etc.

Features

- Wide 4.5V to 18V Operating Input Range
- Adaptive COT Control
- Ultra-fast Load Transient Response
- High Efficiency PFM mode at light load
- High Efficiency Synchronous operation
- No Load IQ 177uA
- Low Rdson Internal Power FETs
- Capable of Delivering 2A
- No External Compensation Needed
- Thermal Shutdown and UVLO
- Available in SOT-563 Package

Applications

- xDSL Modem
- LCD TV
- Set Top Box

Functional Block Diagram

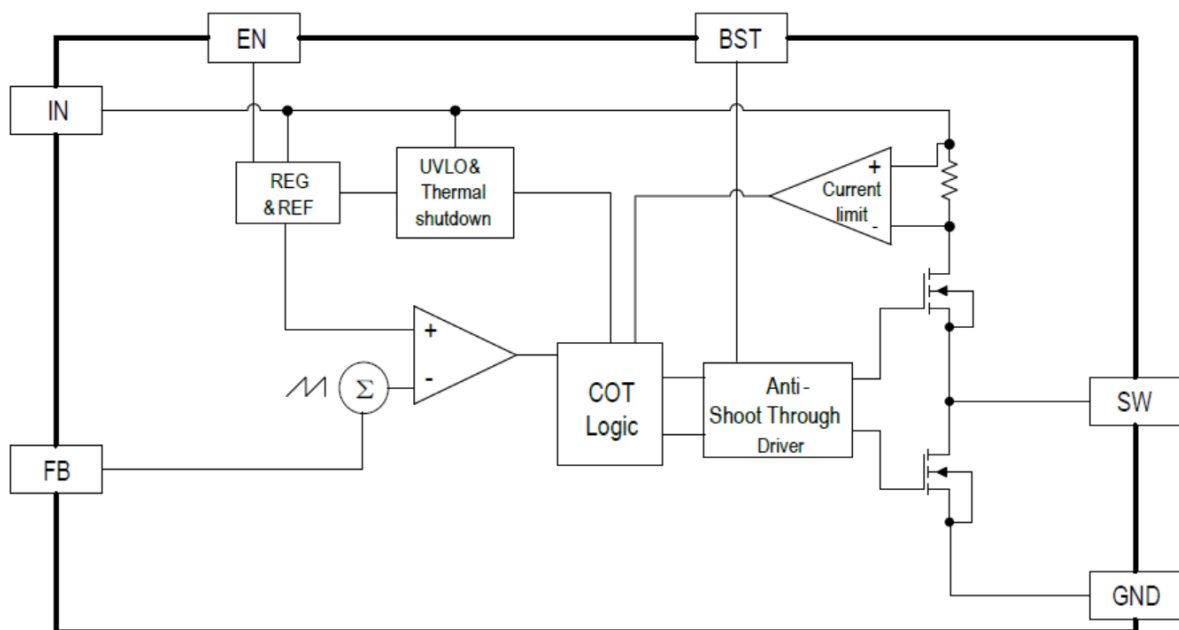

Packages & Pin Assignments

GS5452X7F (SOT-563)	
Pin Name	Description
GND	System Ground. Reference ground of the regulated output voltage, requires extra care during PCB layout.
SW	Switch Output. Connect using wide a PCB trace.
IN	Supply Voltage. The GS5452 operates from a 4.5V to 18V input rail.
FB	Feedback Voltage.
EN	Enable pin for the IC. Drive this pin high to enable the part, Low to disable.
BST	Bootstrap pin. Connect a 10nF capacitor form this pin to SW.

Ordering Information

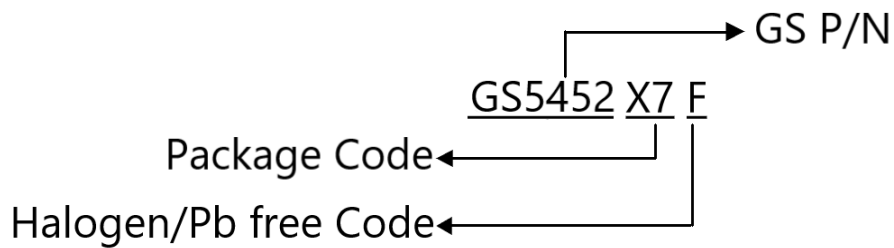

Marking Information

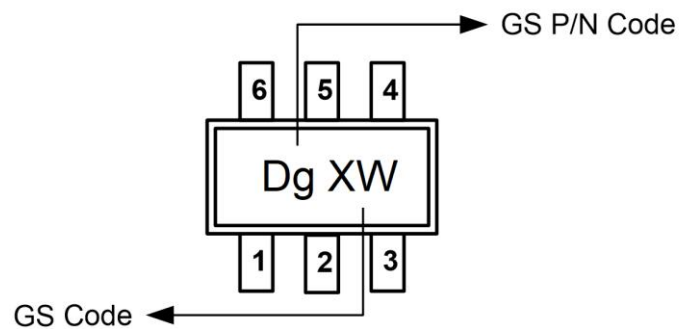

Part Number	Package	Marking	Quantity
GS5452X7F	SOT-563	DgXW	5000 PCS

Absolute Maximum Rating

Symbol	Parameter	Maximum	Unit	
V_{IN}, V_{EN}, V_{SW}	Input , Enable and SW Pin Voltage	-0.3 to 19	V	
V_{BS}	Boost Pin Voltage	-0.3 to $V_{SW}+6$	V	
V_{FB}	Feedback Pin Voltage	-0.3 to 6	V	
T_A	Operating temperature Range	-40 to 85	°C	
T_{STG}	Storage temperature Range	-55 to 150	°C	
T_{LEAD}	Lead temperature (Soldering 10S)	260	°C	
ESD	HBM (Human Body Mode)	2000	V	
	CDM (Charged Device Mode)	1000	V	
θ_{JA}	Thermal Resistance Junction to Ambient	SOT-563	130	°C/W

(Note : Exceeding these limits may damage the device. Exposure to absolute maximum ratings conditions for long periods may affect device reliability.)

Electrical Characteristics

(Typical values $V_{IN}=12V$, $V_{OUT}=3.3V$ with typical $T_A=25^\circ C$, unless otherwise specified)

Symbol	Parameter	Test Conditions	Min	Typ	Max	Units
V_{IN}	Input Voltage Range	-	4.5	-	18	V
V_{UVLO}	UVLO Threshold	Rising, Hysteresis=320mV	-	4.05	-	V
V_{OVP}	OVP Threshold	Rising, Hysteresis=0.9V	-	19	-	V
I_Q	Supply Current	$V_{IN}=12V$, $V_{FB}=0.85V$, $I_{OUT}=0A$, No Switching	-	177	-	μA
I_{SHDN}	Shutdown Current	-	-	7	14	μA
V_{FB}	Feedback Voltage	-	0.781	0.806	0.831	V
V_{FBH}	FB Hiccup Threshold	-	-	0.6	-	V
I_{FB}	Feedback Current	-	-	0	1	μA
$R_{DS(ON)H}$	High-Side Switch on Resistance	-	-	130	-	m Ω
$R_{DS(ON)L}$	Low-Side Switch on Resistance	-	-	65	-	m Ω
T_{SCH}	Short Circuit Hiccup Time	On time	-	2	-	mS
		Off time	-	6	-	mS
I_{SW}	Switch Leakage Current	$V_{IN}=V_{SW}=12V$	-	-	10	μA
F_{SW}	Switching Frequency	-	-	700	-	KHz
I_{LIMIT}	High-Side Current Limit	-	-	3.5	-	A
D_{MAX}	Maximum Duty Cycle	-	-	97	-	%
V_{ENH}	EN Rising Threshold	-	1	1.2	1.4	V
V_{ENL}	EN Falling Threshold	-	0.9	1.1	1.3	V
I_{EN}	EN Input Current	$V_{EN}=2V$	-	2	6	μA
T_{SD}	Thermal Shutdown	Rising, Hysteresis=36°C	-	150	-	°C

Typical Application Circuit

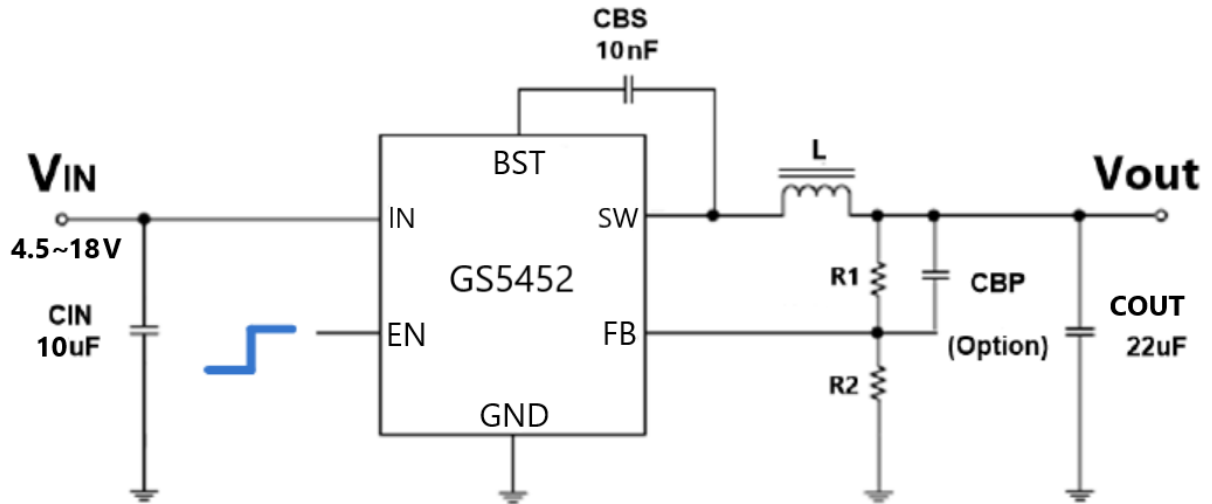

Typical Characteristics

(Typical values are at $T_A=25^\circ\text{C}$ unless otherwise specified)

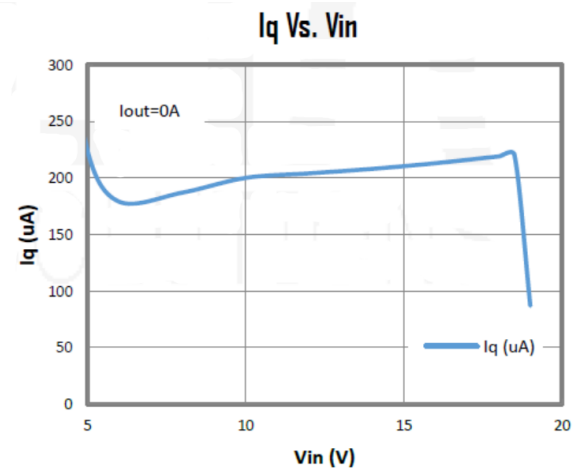
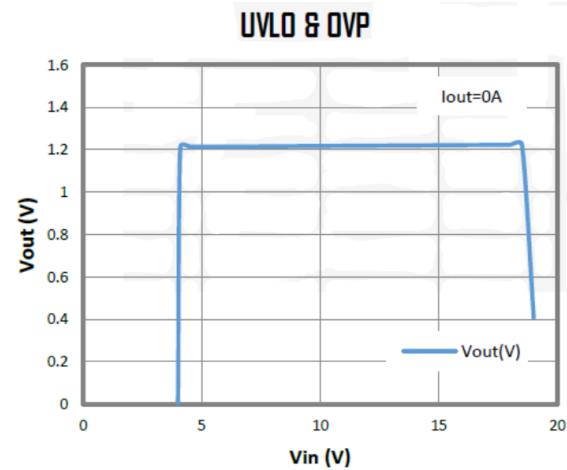
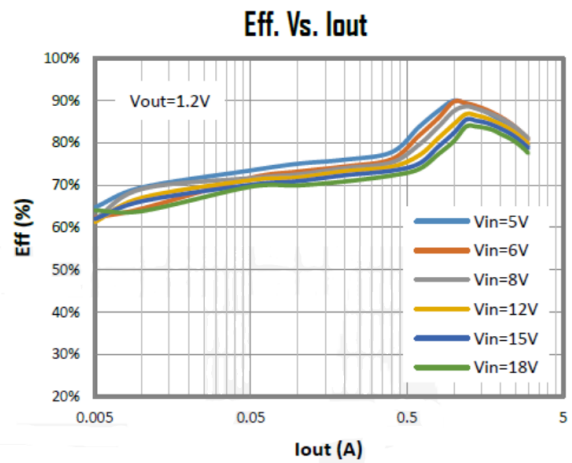
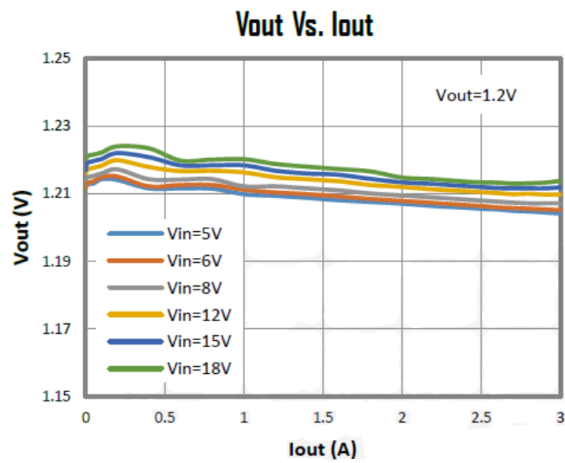

Typical Characteristics(continue)

Vout Vs. Temp

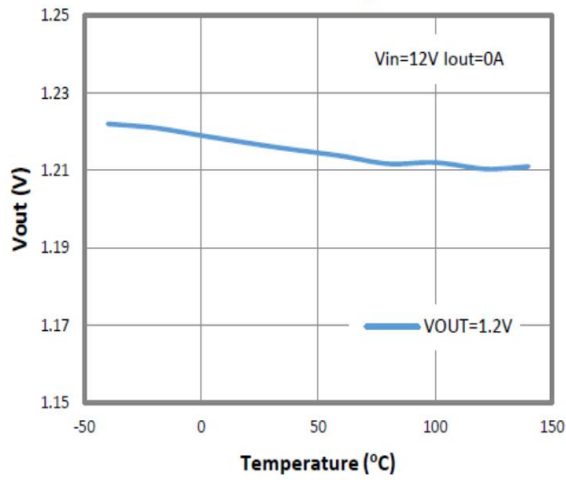

Freq Vs. Temp

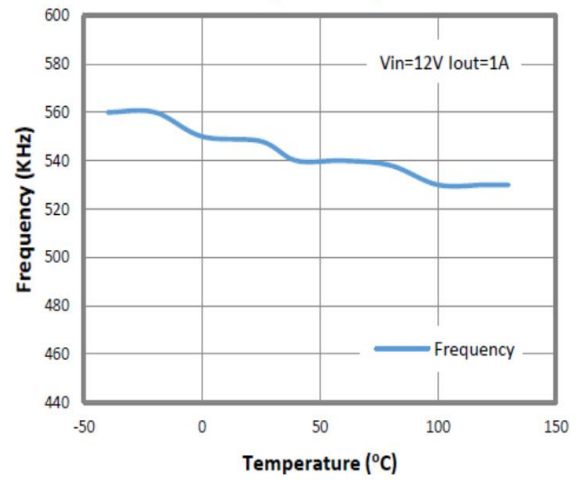

Waveform 1.2V/3A Vin=12V

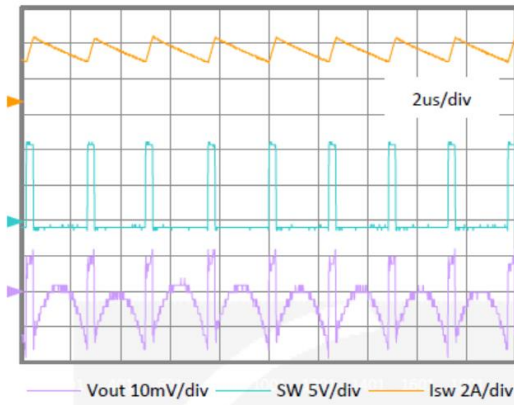

1.2V Load Step 0.3A-2A-0.3A Vin=12V

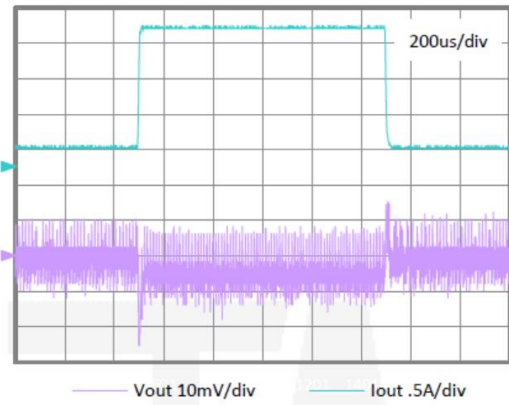

1.2V Load Step rising 0.3A-2A Vin=12V

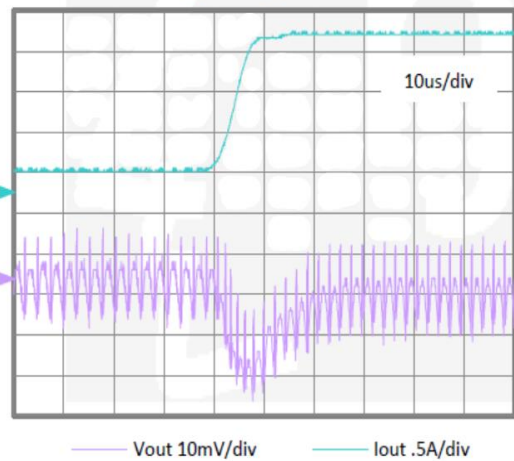

1.2V Load Step falling 2A-0.3A Vin=12V

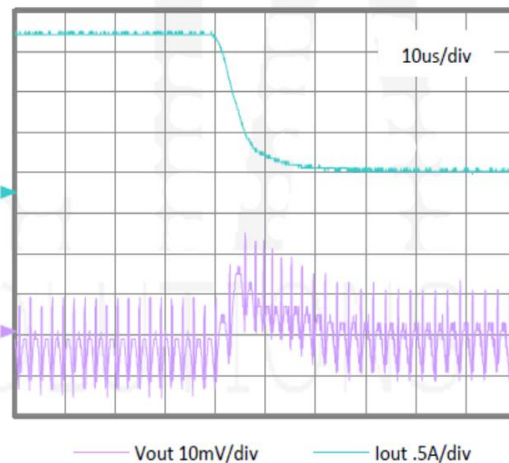

Function Description

The GS5452 is a synchronous buck regulator ICs that integrates the adaptive COT control, top and bottom switches on the same die to minimize the switching transition loss and conduction loss.

GS5452 is a wide input range, high-efficiency and high frequency DC-to-DC step-down switching regulator, capable of delivering up to 2A of output current. It adopts an Adaptive COT control scheme that enables very fast transient response and provides a very smooth transition when the output varies from light load to heavy load. It compares the sum of the FB voltage and a ripple voltage that mimics the voltage due to the output ESR and capacitance. The constant-on-time timer varies with line to achieve relative constant switching frequency across line.

Light Load Operation

Traditionally, a fixed constant frequency PWM DC-DC regulator always switches even when the output load is small. When energy is shuffling back and forth through the power MOSFET, power is lost due to the finite R_{dson} of the MOSFET and parasitic capacitances. At light load, this loss is prominent and efficiency is therefore very low. GS5452 goes into a power save mode during light load, thereby extending the range of high efficiency operation.

Enable

EN is a digital control pin that turns the GS5452 on and off. Drive EN High to turn on the regulator, drive it Low to turn it off. An internal $1M\Omega$ resistor from EN pin to GND allows EN to float to shut down the chip. Connecting the EN pin through a pull up resistor or shorted EN to IN will automatically turn on the chip whenever plug in IN.

Over Current Protection and Hiccup

GS5452 has a cycle-by-cycle over current limit for when the inductor current peak value is over the set current limit threshold. When the output voltage drop until FB falls below UV threshold (0.6V), the GS5452 will enter hiccup mode. It will turn off the chip immediately for 6mS. After that, it will try to re-starts as normal for 2mS. After 2mS, if FB is still below UV threshold, then the chip enters hiccup mode again. If FB is higher than UV threshold, it will enter the normal mode.

Over Temperature Protection

Thermal protection disables the output when the junction temperature rises to approximately 150°C , allowing the device to cool down. When the junction temperature cools to approximately 110°C , the output circuitry is again enabled. Depending on power dissipation, thermal resistance, and ambient temperature, the thermal protection circuit may cycle on and off. This cycling limits regulator dissipation, protecting the device from damage as a result of overheating.

Applications Information

Setting the Output Voltage

The external resistor divider is used to set the output voltage (see Typical Application on page 4).

Where : $V_{FB}=0.806V$ typically (the internal reference voltage)

Resistors R2 has to be between 1kOhm to 20kOhm.

$$V_{OUT} = V_{FB} \times \left(1 + \frac{R_1}{R_2}\right)$$

Inductor

A 2.2 μ H to 4.7 μ H inductor with a DC current rating of at least 25% percent higher than the maximum load current is recommended for most applications. For highest efficiency, the inductor DC resistance should be less than 15m Ω . For most designs, the inductance value can be derived from the following equation.

$V_{out} \geq 3.3V$, $2.2\mu H \leq L \leq 4.7\mu H$.

$V_{out} < 3.3V$, $L = 2.2\mu H$.

$$L = \frac{V_{OUT} \times (V_{IN} - V_{OUT})}{V_{IN} \times \Delta I_L + f_{osc}}$$

Where ΔI_L is the inductor ripple current. Choose inductor ripple current to be approximately 30% if the maximum load current 3A. The maximum inductor peak current is:

$$I_{L(MAX)} = I_{LOAD} + \frac{\Delta I_L}{2}$$

PCB LAYOUT GUIDE

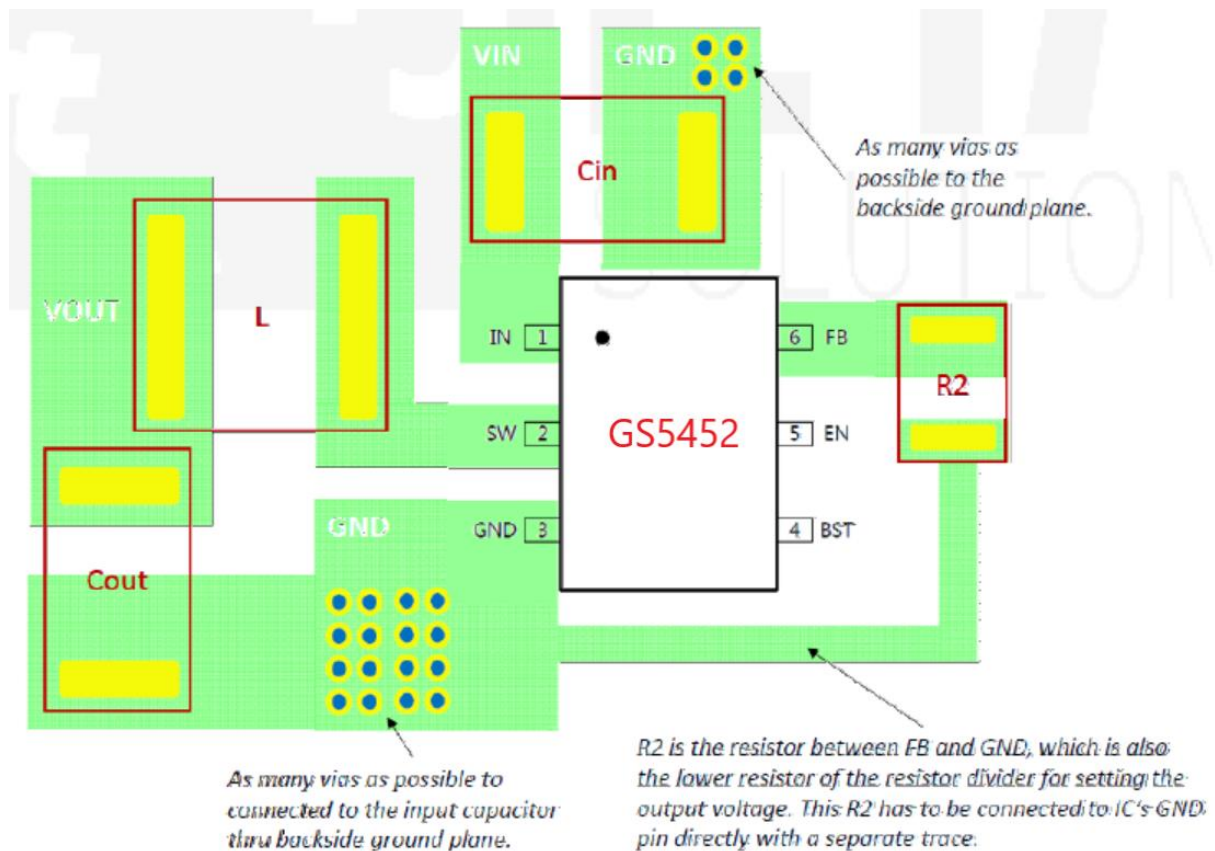

Package Dimension

SOT-563

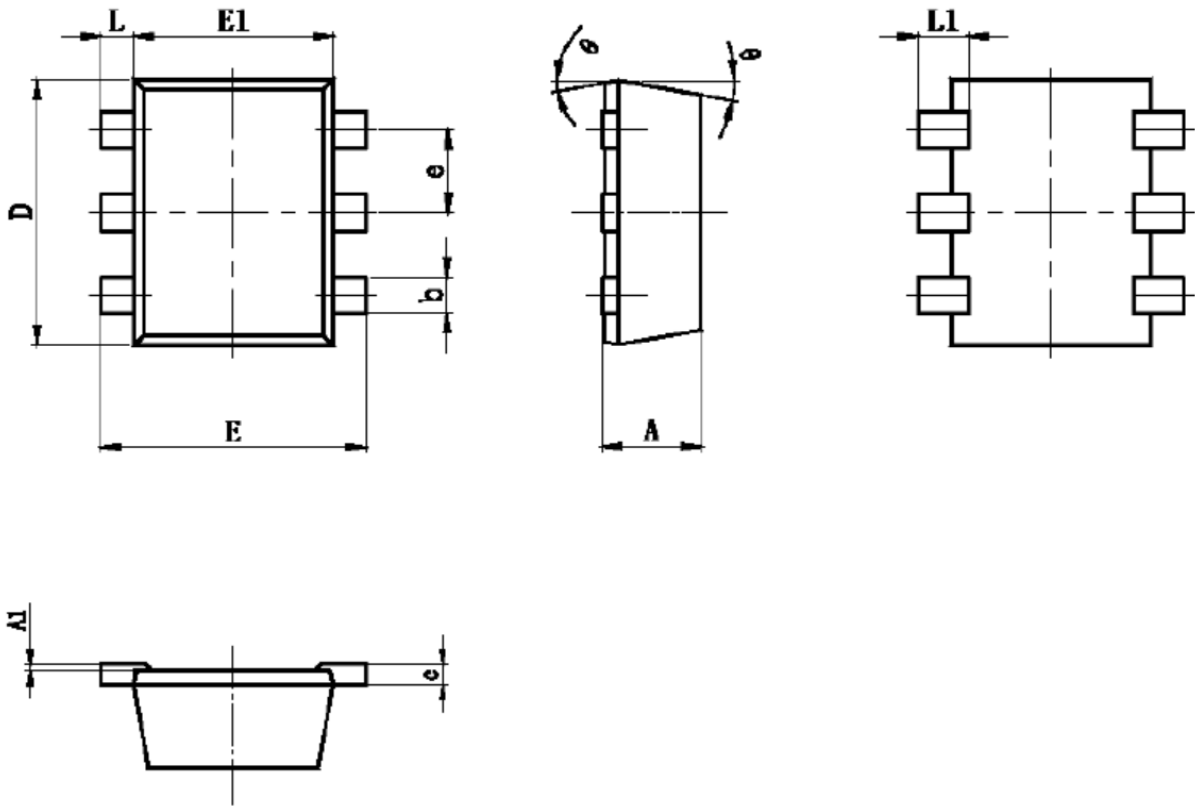





Dimensions



SYMBOL	Millimeters		Inches	
	MIN	MAX	MIN	MAX
A	0.525	0.600	0.021	0.024
A1	0.000	0.050	0.000	0.002
e	0.450	0.550	0.018	0.022
c	0.090	0.180	0.004	0.007
D	1.500	1.700	0.059	0.067
b	0.170	0.270	0.007	0.011
E1	1.100	1.300	0.043	0.051
E	1.500	1.700	0.059	0.067
L	0.100	0.300	0.004	0.012
L1	0.200	0.400	0.008	0.016
θ	9° REF		9° REF	

NOTICE

Information furnished is believed to be accurate and reliable. However Globaltech Semiconductor assumes no responsibility for the consequences of use of such information nor for any infringement of patents or other rights of third parties, which may result from its use. No license is granted by implication or otherwise under any patent or patent rights of Globaltech Semiconductor. Specifications mentioned in this publication are subject to change without notice. This publication supersedes and replaces all information without express written approval of Globaltech Semiconductor.

CONTACT US

GS Headquarter	
	4F.,No.43-1,Lane11,Sec.6,Minquan E.Rd Neihu District Taipei City 114, Taiwan (R.O.C)
	886-2-2657-9980
	886-2-2657-3630
	sales_twn@gs-power.com

RD Division	
	824 Bolton Drive Milpitas. CA. 95035
	1-408-457-0587