

GS5421ARF

28V 2A 500KHz Synchronous Step-Down Converter

Product Description

The GS5421ARF is a high frequency, synchronous, rectified, step-down, switch-mode converter with internal power MOSFETs.

It offers a very compact solution to provide a 2A continuous output current over a wide input supply range, with excellent load and line regulation. ECOT control operation provides very fast transient response and easy loop design as well as very tight output regulation.

The GS5421ARF requires a minimal number of readily available, external components and is available in a space saving SOT-23-6L package.

Features

- Wide 4.5V to 28V Operating Input Range
- 2A Continuous Output Current
- 500KHz Switching Frequency
- ECOT Mode Control with Fast Transient Response
- Built-in Over Current Limit
- Built-in Over Voltage Protection (For Input)
- PFM Mode for High Efficiency in Light Load
- Internal Soft-Start
- 100mΩ/50mΩ Low RDS(ON) Internal Power MOSFETs
- No Schottky Diode Required
- Short Protection with Hiccup-Mode
- Integrated internal compensation
- Thermal Shutdown
- Available in SOT-23-6L Package
- -40°C to +85°C Temperature Range

Applications

- Automotive Systems
- Network Terminal Equipment
- Security Monitoring Camera
- Printer Systems
- Industrial Power Systems
- Distributed Power Systems

Functional Block Diagram

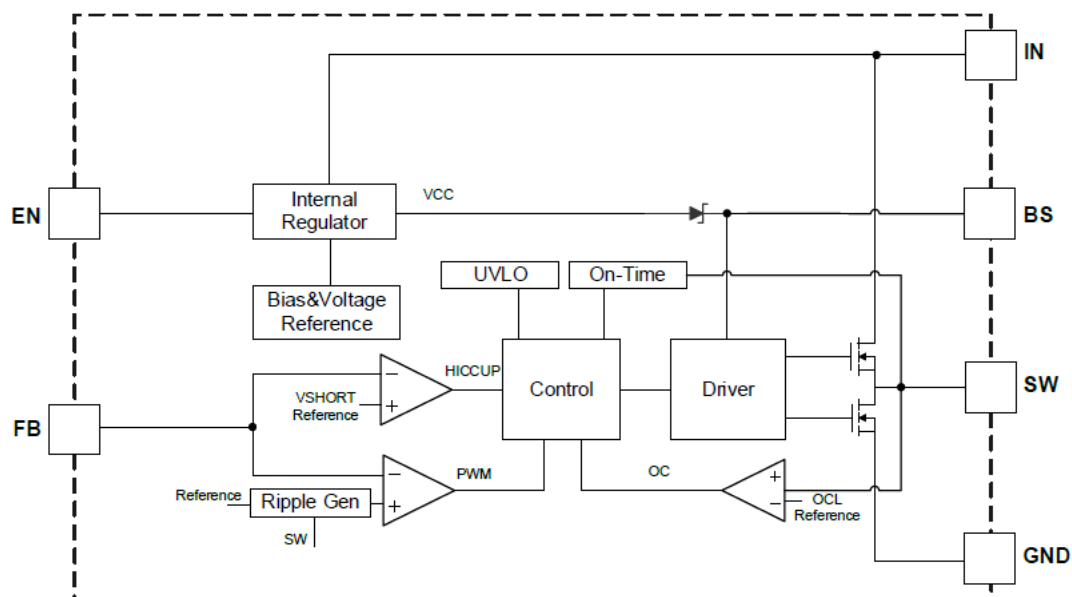

Packages & Pin Assignments

GS5421ARF (SOT-23-6L)		
<p style="text-align: center;">(Top View)</p>		
Pin	Name	Description
1	BS	Bootstrap. A capacitor connected between SW and BST pins is required to form a floating supply across the high-side switch driver.
2	GND	Ground Pin.
3	FB	Adjustable Version Feedback input. Connect FB to the center point of the external resistor divider.
4	EN	Drive this pin to a logic-high to enable the IC. Drive to a logic-low to disable the IC and enter micro-power shutdown mode.
5	V _{IN}	Power Supply Pin.
6	SW	Switch Output. Connect using wide a PCB trace.

Ordering & Marking Information

Ordering Information				
Part Number	Package	V _{FB}	F _{SW}	Qty/Reel
GS5421ARF	SOT-23-6L	0.8V	500KHz	3000 PCS
Product Code: GS5421A	Package Code: R for SOT-23-6L	Green Level: F stands for RoHS Compliant and Halogen Free		
Marking Information				
Product Code: Gq	GS Code: □□□ is GS Code			

Absolute Maximum Rating (T_A=25°C, unless otherwise specified) ^{1,2}

Symbol	Parameter	Range	Unit
V _{IN}	Input Voltage	-0.3 to 32	V
V _{EN}	Enable Voltage	-0.3 to 32	V
V _{SW}	Switch Voltage	-0.3 to V _{IN} +1V	V
V _{BS}	BS Voltage	-0.3 to V _{SW} +6V	V
V _{FB}	Feedback Voltage	-0.3 to 6	V
P _D	Power Dissipation ³	1.19	W
T _J	Max Junction Temperature	150	°C
T _{STG}	Storage Temperature Range	-55 to 150	°C
T _{LEAD}	Lead Temperature (Soldering 10 Sec.)	260	°C
R _{θJA}	Junction-to-Ambient Thermal Resistance ^{4,5}	105	°C/W
ESD	HBM (Human Body Mode)	±2000	V
	CDM (Charged Device Mode)	±200	V
I _{Latch-Up}	LATCH-UP	±150	mA

Recommended Operating Conditions

Symbol	Parameter	Range	Unit
T _J	Operating junction temperature ⁶	-40 to 125	°C
V _{IN}	Input voltage	4.5 to 28	V
V _{OUT}	Output current	0 to 2	A

Note:

- Exceeding these ratings may damage the device.
- The device is not guaranteed to function outside of its operating conditions.
- The maximum allowable power dissipation is a function of the maximum junction temperature, T_{J(MAX)}, the junction-to-ambient thermal resistance, R_{θJA}, and the ambient temperature, T_A. The maximum allowable power dissipation at any ambient temperature is calculated using P_{D(MAX)} = (T_{J(MAX)} - T_A)/R_{θJA}. Exceeding the maximum allowable power dissipation causes excessive die temperature, and the regulator goes into thermal shutdown. Internal thermal shutdown circuitry protects the device from permanent damage. Thermal shutdown engages at T_J=160°C (typical) and disengages at T_J= 130°C (typical).
- The package thermal impedance is calculated in accordance to JESD 51-7.
- Thermal Resistances were simulated on a 4-layer, JEDEC board.
- All limits specified at room temperature (T_A = 25°C) unless otherwise specified. All room temperature limits are 100% production tested. All limits at temperature extremes are ensured through correlation using standard Statistical Quality Control (SQC) methods. All limits are used to calculate Average Outgoing Quality Level (AOQL).

Electrical Characteristics (V_{IN}=12V, T_A=25°C, unless otherwise specified) ^{7,8}

Symbol	Parameter	Test Conditions	Min	Typ	Max	Units
V _{IN}	Input Voltage Range		4.5	-	28	V
I _Q	Quiescent Current	V _{EN} =3V	-	0.6	0.8	mA
I _{SHDN}	Shutdown Current	V _{EN} =0V or EN=GND	-	-	4	μA
V _{FB}	Feedback Voltage		0.780	0.80	0.820	V
R _{DS(ON)H}	High-Side Switch On-Resistance	I _{SW} =100mA	-	100	-	mΩ
R _{DS(ON)L}	Low-Side Switch On-Resistance	I _{SW} =-100mA	-	50	-	mΩ
F _{SW}	Switching Frequency		-	500	-	KHz
D _{MAX}	Maximum Duty Cycle	V _{FB} =90%	-	85	-	%
T _{OFF(MIN)}	Minimum Off-Time		-	200	-	nS
V _{ENH}	EN Rising Threshold		1.2	-	-	V
V _{ENL}	EN Falling Threshold		-	-	0.9	V
I _{LIMIT}	Valley Switch Current Limit		2.5	-	-	A
OVP	Over Voltage Protection Threshold (for Input)		-	28.5	-	V
V _{UVLO}	UVLO Threshold		3.0	-	4.2	V
ΔV _{UVLO}	UVLO Threshold Hysteresis		-	400	-	mV
t _{SS}	Soft Start			1.5	-	mS
T _{SD}	Thermal Shutdown		-	160	-	°C
ΔT _{SD}	Thermal Hysteresis		-	30	-	°C

Note:

7. MOSFET on-resistance specifications are guaranteed by correlation to wafer level measurements.
8. Thermal shutdown specifications are guaranteed by correlation to the design and characteristics analysis.

Typical Characteristics ($V_{IN}=12V$, $V_{OUT}=3.3V$, $T_A=25^{\circ}C$ unless otherwise specified)

Load Regulation

$V_{OUT}=5V, 3.3V, 1.2V$

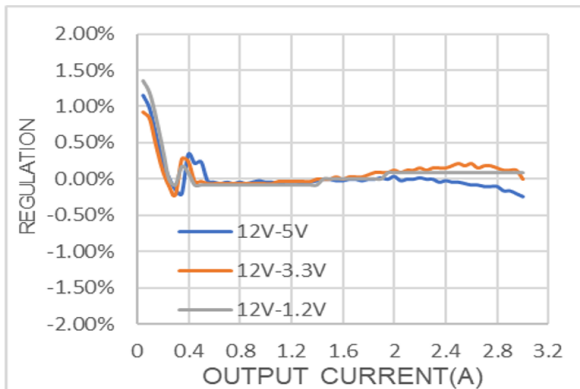

Line Regulation

$V_{OUT}=3.3V$

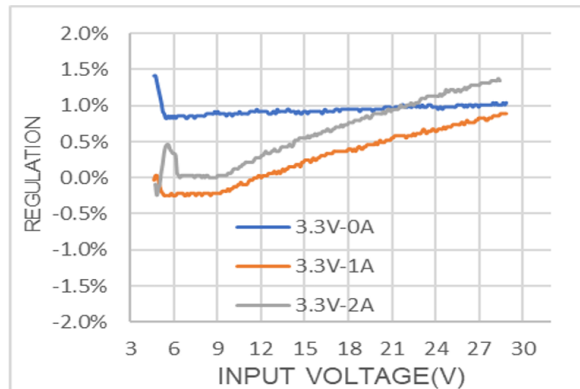

Efficiency vs Load Current

$V_{OUT}=5V, 3.3V, 1.2V$

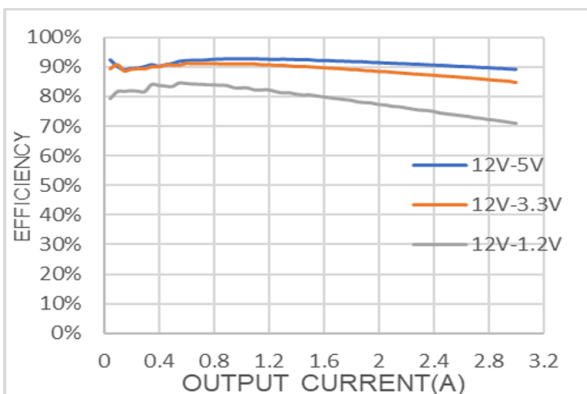

Output Ripple Voltage

$V_{IN}=12V, V_{OUT}=3.3V, I_{OUT}=0A$

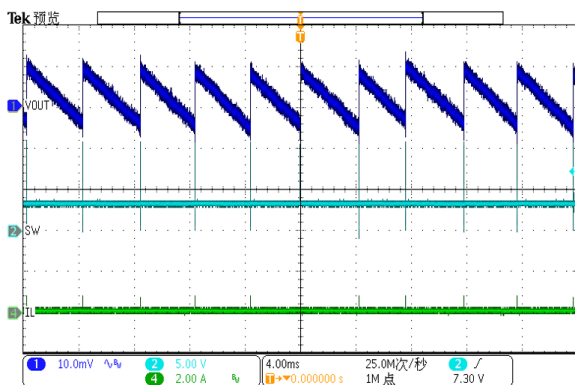

Output Ripple Voltage

$V_{IN}=12V, V_{OUT}=3.3V, I_{OUT}=2A$

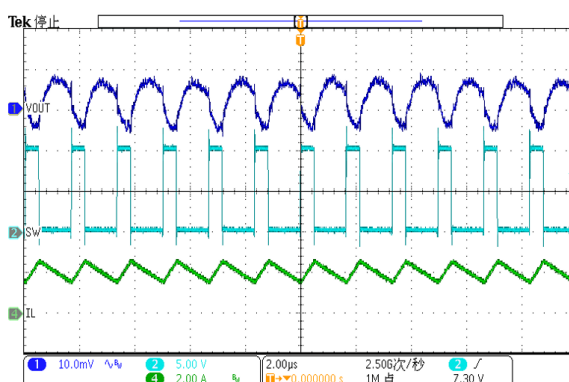

Loop Response

$V_{IN}=12V, V_{OUT}=3.3V, I_{OUT}=1A-2A$

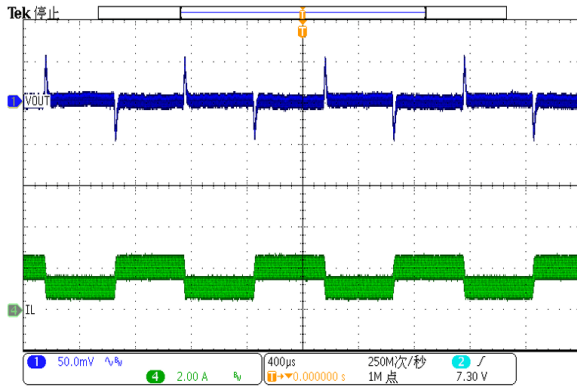

Output Short

$V_{IN}=12V, V_{OUT}=3.3V$

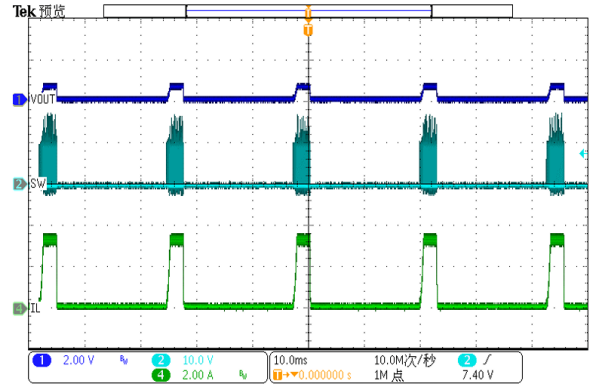

Short Circuit Entry

$V_{IN}=12V, V_{OUT}=3.3V$

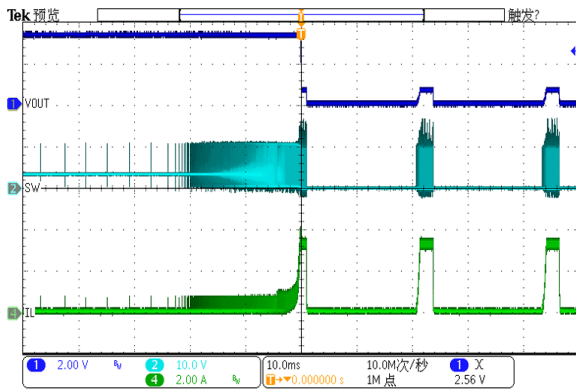

Short Circuit Recovery

$V_{IN}=12V, V_{OUT}=3.3V$

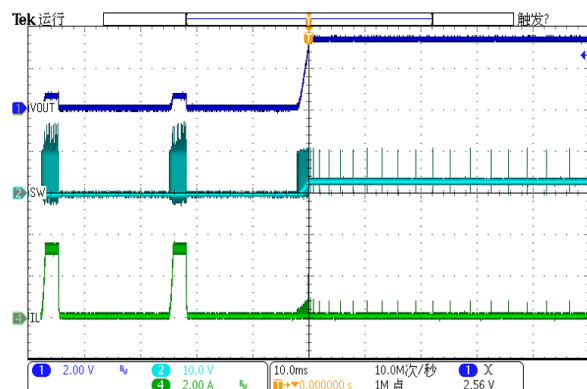

Enable Startup at No Load

$V_{IN}=12V, V_{OUT}=3.3V, I_{OUT}=0A$

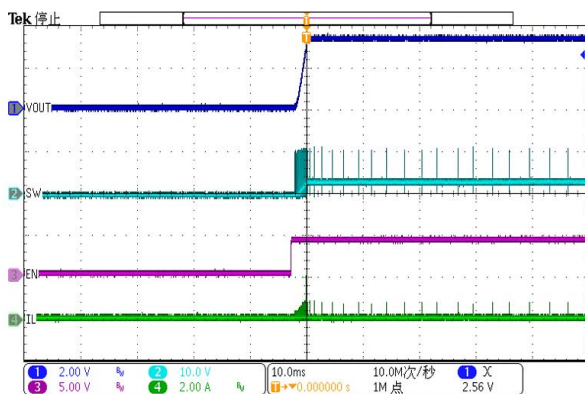

Enable Shutdown at No Load

$V_{IN}=12V, V_{OUT}=3.3V, I_{OUT}=0A$

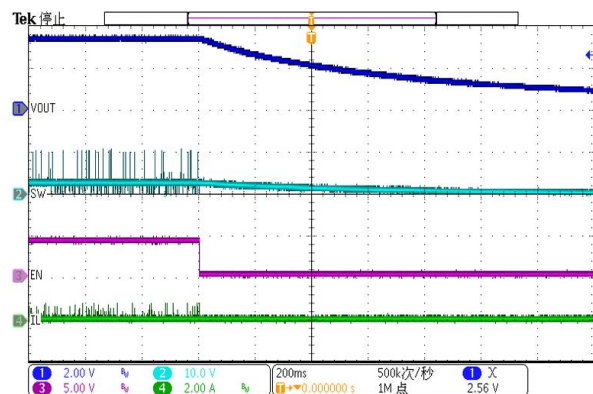

Enable Startup at Full Load

$V_{IN}=12V$, $V_{OUT}=3.3V$, $I_{OUT}=2A$

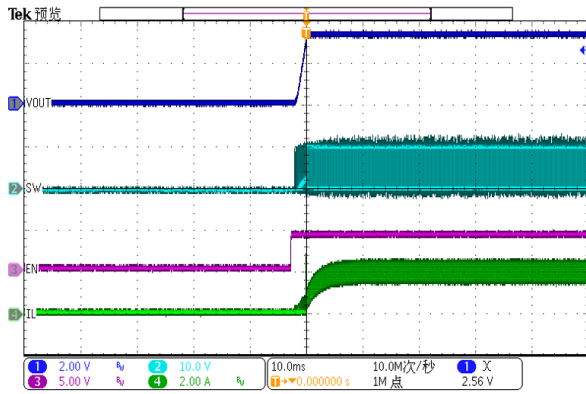

Enable Shutdown at Full Load

$V_{IN}=12V$, $V_{OUT}=3.3V$, $I_{OUT}=2A$

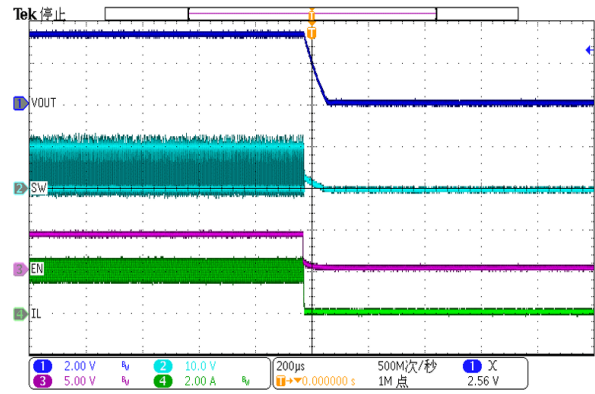

Power Up at No Load

$V_{IN}=12V$, $V_{OUT}=3.3V$, $I_{OUT}=0A$

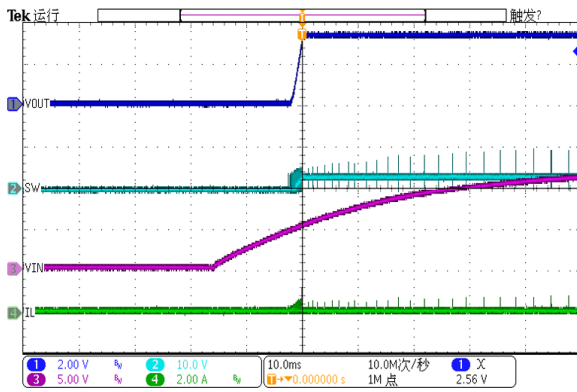

Power Up at Full Load

$V_{IN}=12V$, $V_{OUT}=3.3V$, $I_{OUT}=2A$

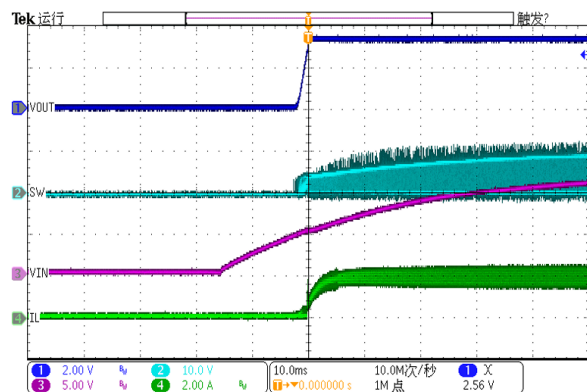

Function Description

Internal Regulator

The GS5421ARF is an ECOT mode step down DC/DC converter that provides excellent transient response with no extra external compensation components. This device contains an internal, low resistance, high voltage power MOSFET, and operates at a high 500KHz operating frequency to ensure a compact, high efficiency design with excellent AC and DC performance.

Error Amplifier

The error amplifier compares the FB pin voltage with the internal FB reference (V_{FB}) and outputs a current proportional to the difference between the two. This output current is then used to charge or discharge the internal compensation network, which is used to control the power MOSFET current. The optimized internal compensation network minimizes the external component counts and simplifies the control loop design.

Under-Voltage Lockout (UVLO)

Under-voltage lockout (UVLO) protects the chip from operating at an insufficient supply voltage. UVLO protection monitors the internal regulator voltage. When the voltage is lower than UVLO threshold voltage, the device is shut off. When the voltage is higher than UVLO threshold voltage, the device is enabled again.

Thermal Shutdown

Thermal shutdown prevents the chip from operating at exceedingly high temperatures. When the silicon die temperature exceeds 160°C, it shuts down the whole chip. When the temperature falls below its lower threshold (Typ. 130°C) the chip is enabled again.

Internal Soft-Start

The soft-start is implemented to prevent the converter output voltage from overshooting during startup. When the chip starts, the internal circuitry generates a soft-start voltage (SS) ramping up from 0V to 0.805V. When it is lower than the internal reference (REF), SS overrides REF so the error amplifier uses SS as the reference. When SS is higher than REF, REF regains control. The SS time is 1.5ms approximately.

Over Current Protection and Hiccup

The GS5421ARF has cycle-by-cycle over current limit when the inductor current valley value exceeds the set current limit threshold. Meanwhile, output voltage starts to drop until FB is below the Under-Voltage (UV) threshold. Once a UV is triggered, the GS5421ARF enters hiccup mode to periodically restart the part. This protection mode is especially useful when the output is dead-short to ground. The average short circuit current is greatly reduced to alleviate the thermal issue and to protect the regulator. The GS5421ARF exits the hiccup mode once the over current condition is removed.

Startup and Shutdown

If both V_{IN} and EN are higher than their appropriate thresholds, the chip starts. The reference block starts first, generating stable reference voltage and currents, and then the internal regulator is enabled. The regulator provides stable supply for the remaining circuitries. Three events can shut down the chip: EN low, V_{IN} low and thermal shutdown. In the shutdown procedure, the signaling path is first blocked to avoid any fault triggering. The comp voltage and the internal supply rail are then pulled down. The floating driver is not subject to this shutdown command.

Typical Applications Circuit

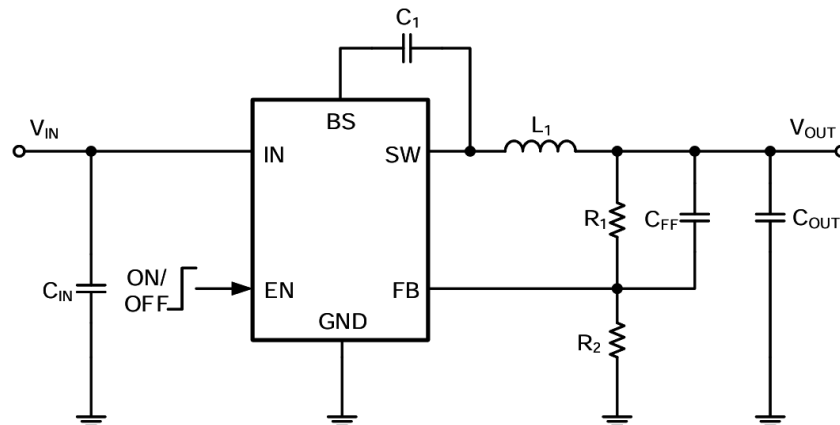

Applications Information

Setting the Output Voltage

GS5421ARF requires an input capacitor, an output capacitor and an inductor. These components are critical to the performance of the device. GS5421ARF are internally compensated and do not require external components to achieve stable operation. The output voltage can be programmed by resistor divider.

$$V_{OUT} = V_{FB} \times \frac{R1 + R2}{R2}$$

V _{OUT} (V)	R1(KΩ)	R2(KΩ)	L1(μH)	C1(nF)	C _{IN} (μF)	C _{OUT} (μF)	C _{FF} (pF) Opt.
1.0	2.50	10	1.0	100	22	22x2	C _{FF} Chapter
1.2	5.00	10	1.5	100	22	22x2	C _{FF} Chapter
1.5	8.75	10	2.2	100	22	22x2	C _{FF} Chapter
1.8	12.50	10	2.2	100	22	22x2	C _{FF} Chapter
2.5	21.25	10	2.2	100	22	22x2	C _{FF} Chapter
3.3	31.25	10	3.3	100	22	22x2	C _{FF} Chapter
5.0	52.50	10	4.7	100	22	22x2	C _{FF} Chapter

*All the external components are the suggested values; the final values are based on the application testing results.

Selecting the Inductor

The recommended inductor values are shown in the table above. It is important to guarantee the inductor core does not saturate during any foreseeable operational situation. The inductor should be rated to handle the maximum inductor peak current: Care should be taken when reviewing the different saturation current ratings that are specified by different manufacturers. Saturation current ratings are typically specified at 25°C, so ratings at maximum ambient temperature of the application should be requested from the manufacturer. The inductor value can be calculated with:

$$L = \frac{V_{OUT} \times (V_{IN} - V_{OUT})}{V_{IN} \times \Delta I_L \times F_{OSC}}$$

Where ΔI_L is the inductor ripple current. Choose inductor ripple current to be approximately 30% to 40% of the maximum load current. The maximum inductor peak current can be estimated as:

$$I_{L(MAX)} = I_{LOAD} + \frac{\Delta I_L}{2}$$

Under light load conditions below 100mA, larger inductance is recommended for improved efficiency. Larger inductances lead to smaller ripple currents and voltages, but they also have larger physical dimensions, lower saturation currents and higher linear impedance. Therefore, the choice of inductance should be compromised according to the specific application.

Selecting the Input Capacitor

The input current to the step-down converter is discontinuous and therefore requires a capacitor to supply AC current to the step-down converter while maintaining the DC input voltage. For better performance, use ceramic capacitors placed as close to VIN as possible and a 0.1μF input capacitor to filter out high frequency interference is recommended. Capacitors with X5R and X7R ceramic dielectrics are recommended because they are stable with temperature fluctuations.

The capacitors must also have a ripple current rating greater than the maximum input ripple current of the converter. The input ripple current can be estimated with Equation:

$$I_{CIN} = I_{OUT} \times \sqrt{\frac{V_{OUT}}{V_{IN}} \times \left(1 - \frac{V_{OUT}}{V_{IN}}\right)}$$

From the above equation, it can be concluded that the input ripple current reaches its maximum at $V_{IN}=2V_{OUT}$ where $I_{CIN} = \frac{I_{OUT}}{2}$. for simplification, choose an input capacitor with an RMS current rating greater than half of the maximum load current.

The input capacitance value determines the input voltage ripple of the converter. If there is an input voltage ripple requirement in the system, choose the input capacitor that meets the specification. The input voltage ripple can be estimate with Equation:

$$\Delta V_{IN} = \frac{I_{OUT}}{F_{OSC} \times C_{IN}} \times \frac{V_{OUT}}{V_{IN}} \times \left(1 - \frac{V_{OUT}}{V_{IN}}\right)$$

Similarly, when $V_{IN}=2V_{OUT}$, input voltage ripple reaches its maximum of $\Delta V_{IN} = \frac{1}{4} \times \frac{I_{OUT}}{F_{OSC} \times C_{IN}}$.

Selecting the Output Capacitor

An output capacitor is required to maintain the DC output voltage. The output voltage ripple can be estimated with Equation:

$$\Delta V_{OUT} = \frac{V_{OUT}}{F_{OSC} \times L} \times \left(1 - \frac{V_{OUT}}{V_{IN}}\right) \times \left(R_{ESR} + \frac{1}{8 \times F_{OSC} \times C_{OUT}}\right)$$

There are some differences between different types of capacitors. In the case of ceramic capacitors, the impedance at the switching frequency is dominated by the capacitance. The output voltage ripple is mainly caused by the capacitance. For simplification, the output voltage ripple can be estimated with Equation:

$$\Delta V_{OUT} = \frac{V_{OUT}}{8 \times F_{OSC}^2 \times L \times C_{OUT}} \times \left(1 - \frac{V_{OUT}}{V_{IN}}\right)$$

A larger output capacitor can achieve a better load transient response, but the maximum output capacitor limitation should also be considered in the design application. If the output capacitor value is too high, the output voltage will not be able to reach the design value during the soft-start time and will fail to regulate. The maximum output capacitor value (C_{OUT_MAX}) can be limited approximately with Equation:

$$C_{OUT_MAX} = (I_{LIM_AVG} - I_{OUT}) \times T_{SS} / V_{OUT}$$

Where L_{LIM_AVG} is the average start-up current during the soft-start period, and T_{SS} is the soft- start time. On the other hand, special attention should be paid when selecting these components. The DC bias of these capacitors can result in a capacitance value that falls below the minimum value given in the recommended capacitor specifications table.

The ceramic capacitor's actual capacitance can vary with temperature. The capacitor type X7R, which operates over a temperature range of -55°C to $+125^{\circ}\text{C}$, will only vary the capacitance to within $\pm 15\%$. The capacitor type X5R has a similar tolerance over a reduced temperature range of -55°C to $+85^{\circ}\text{C}$. Many large value ceramic capacitors, larger than 1μF are manufactured with Z5U or Y5V temperature characteristics. Their capacitance can drop by more than 50% as the temperature varies from 25°C to 85°C . Therefore, X5R or X7R is recommended over Z5U and Y5V in applications where the ambient temperature will change significantly above or below 25°C .

Feed-Forward Capacitor (C_{FF})

GS5421ARF has internal loop compensation, so adding C_{FF} is optional. Specifically, for specific applications, if necessary, consider whether to add feed-forward capacitors according to the situation.

The use of a feed-forward capacitor (C_{FF}) in the feedback network is to improve the transient response or higher phase margin. For optimizing the feed-forward capacitor, knowing the cross frequency is the first thing. The cross frequency (or the converter bandwidth) can be determined by using a network analyzer. When getting the cross frequency with no feed-forward capacitor identified, the value of feed-forward capacitor (C_{FF}) can be calculated with the following equation:

$$C_{FF} = \frac{1}{2\pi \times F_{CROSS}} \times \sqrt{\frac{1}{R1} \times \left(\frac{1}{R1} + \frac{1}{R2}\right)}$$

Where F_{CROSS} is the cross frequency.

To reduce transient ripple, the feed-forward capacitor value can be increased to push the cross frequency to a higher region. Although this can improve transient response, it also decreases phase margin and causes more ringing. In the other hand, if more phase margin is desired, the feed-forward capacitor value can be decreased to push the cross frequency to lower region.

PCB Layout Consideration

1. PCB layout is very important to achieve stable operation. It is highly recommended to duplicate EVB layout for optimum performance. If change is necessary, please follow these guidelines for reference.
2. Keep the path of switching current short and minimize the loop area formed by Input capacitor, high-side MOSFET and low-side MOSFET.
3. Bypass ceramic capacitors are suggested to be put close to the VIN Pin.
4. Ensure all feedback connections are short and direct. Place the feedback resistors and compensation components as close to the chip as possible.
5. VOUT, SW away from sensitive analog areas such as FB.
6. Connect IN, SW, and especially GND respectively to a large copper area to cool the chip to improve thermal performance and long-term reliability.

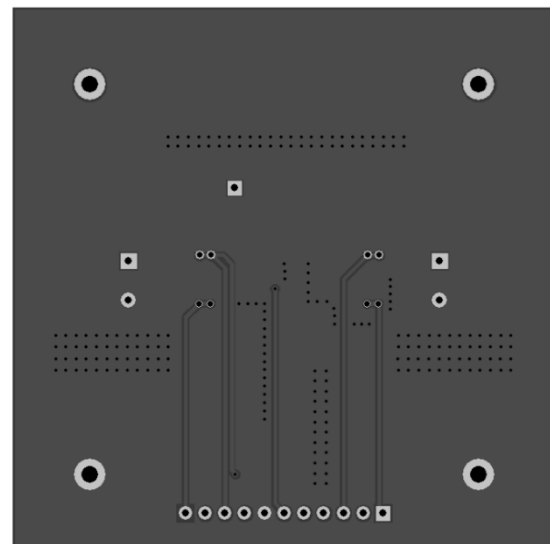
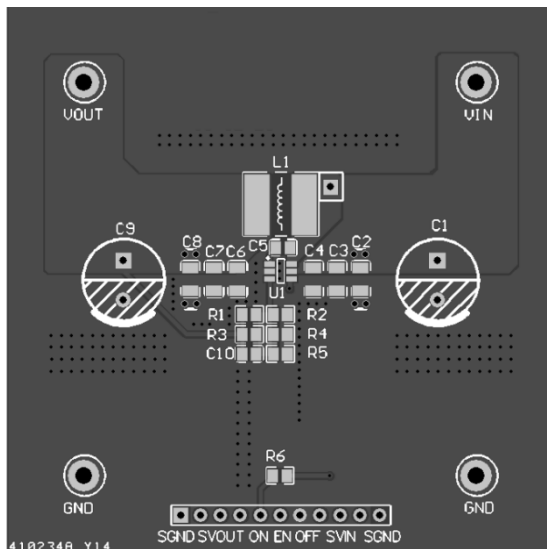

SOT-23-6L

Package Dimension

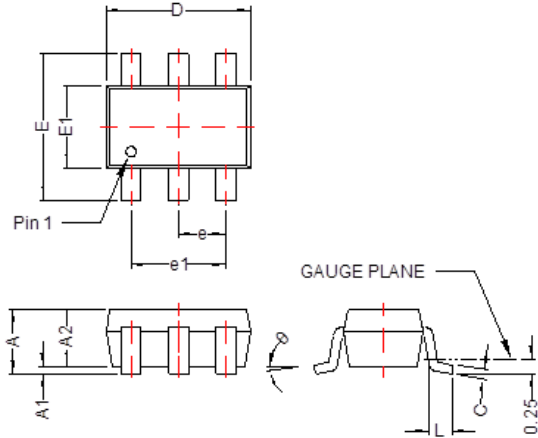

Recommended Land Pattern

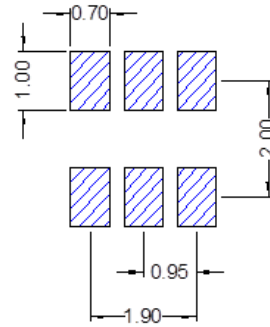

Dimensions				
SYMBOL	Millimeters		Inches	
	MIN	MAX	MIN	MAX
A	0.90	1.45	0.035	0.057
A1	0.00	0.15	0.000	0.006
A2	0.90	1.30	0.035	0.051
b	0.30	0.50	0.012	0.020
c	0.08	0.26	0.003	0.010
D	2.70	3.10	0.106	0.122
E	2.20	3.00	0.087	0.118
E1	1.30	1.75	0.051	0.069
e	0.95 BSC		0.037 BSC	
e1	1.90 BSC		0.075 BSC	
L	0.3	0.6	0.012	0.024
θ	0°	8°	0°	8°





NOTE :



Dimensions are exclusive of Burrs, Mold Flash & Tie Bar extrusions.

NOTICE

- Globaltech Semiconductor assumes no responsibility for equipment failures that result from using products at values that exceed, even momentarily, rated values (such as maximum ratings, operating condition ranges, or other parameters) listed in products specifications of any and all Globaltech Semiconductor products described or contained herein. Globaltech Semiconductor products are not designed for use in life support appliances, devices or systems where malfunction of these products can be reasonably expected to result in personal injury. Reproduction in whole or in part is prohibited without the prior written consent of the copyright owner.
- Applications shown on the herein document are examples of standard use and operation. Customers are responsible in comprehending the suitable use in particular applications. Globaltech Semiconductor makes no representation or warranty that such applications will be suitable for the specified use without further testing or modification.
- Information furnished is believed to be accurate and reliable. However Globaltech Semiconductor assumes no responsibility for the consequences of use of such information nor for any infringement of patents or other rights of third parties, which may result from its use. No license is granted by implication or otherwise under any patent or patent rights of Globaltech Semiconductor. Specifications mentioned in this publication are subject to change without notice. This publication supersedes and replaces all information without express written approval of Globaltech Semiconductor.

CONTACT US

GS Headquarter	
	4F.,No.43-1,Lane11,Sec.6,Minquan E.Rd Neihsu District Taipei City 114, Taiwan (R.O.C)
	886-2-2657-9980
	886-2-2657-3630
	sales_twn@gs-power.com

RD Division	
	824 Bolton Drive Milpitas. CA. 95035
	1-408-457-0587