

GS2823 Series

300mA High PSRR Low Dropout Voltage Linear Regulator

Product Description

The GS2823 is a low dropout and low noise linear regulator with high ripple rejection ratio and fast turn-on time. GS2823 is a fixed output voltage type. It has a fixed output voltage ranging from 1.2V to 4V.

The GS2823 includes a voltage reference unit, an error amplifier, resistor net for voltage setting, a current limit circuit and a chip enable circuit.

The GS2823 works well with low ESR ceramic capacitors, suitable for portable RF and wireless battery-powered applications with stringent space requirements and demanding performance. It also offers ultra low noise output and has low quiescent current.

Features

- Output Current: 300mA
- High Ripple Rejection: 80dB (Typ) (f=1kHz)
- Output Voltage:
Vout ≥ 2V (Accuracy ±1.0%)
Vout < 2V (Accuracy ±20mV)
- Low Supply Current: 150µA (Typ)
- Standby Current: 0.1µA (Typ)
- EN Function: Active High
- Operating Ambient Temperature: -40~+85°C
- Current Limit and Short Circuit Protection
- Fixed Output Voltage: 1.2V to 4.0V
- Low ESR Capacitors: C_{in}=1µF, C_L=1µF
- Small Packages: SOT-23, SOT-23-5L, DFN1x1-4L
- RoHS Compliant & Halogen Free

Applications

- Mobile Devices
- Portable Communication Equipment
- Modules
- Hand-Held Instruments
- Wireless Communications

Functional Block Diagram

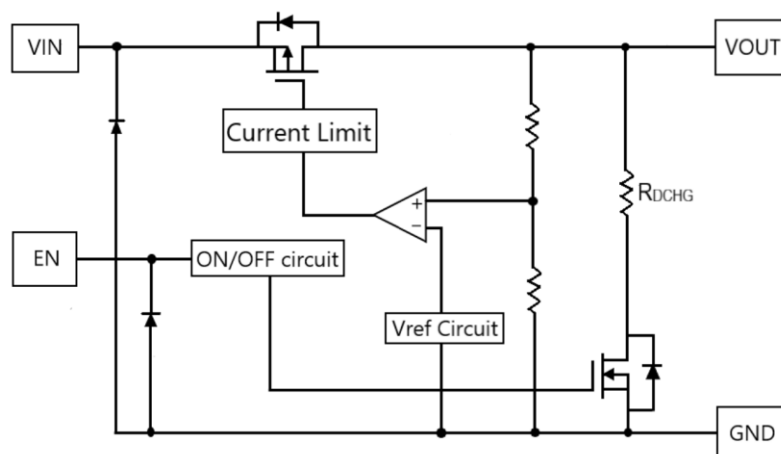

Packages & Pin Assignments

SOT-23	SOT-23-5L	DFN1X1-4L
Pin Name	Function	
V _{IN}	Power Supply Input.	
V _{OUT}	The pin is the power output of the device.	
GND	Ground Pin.	
EN	Enable Input. Pulling this pin below 0.3V turn the regulator off, reducing the quiescent current to a fraction of its operating value. The device will be enabled if this pin is left open. Connect to V _{IN} if not being used.	
NC	No Connect.	

Ordering and Marking Information

Ordering Information					
SOT-23	SOT-23-5L	Marking	DFN1x1-4L	Marking	Output Voltage
GS2823Z12F	GS2823L12F	CXD□□□	GS2823F12F GS2823F12F1	XD □□	1.2V
GS2823Z15F	GS2823L15F	CXG□□□	GS2823F15F GS2823F15F1	XG □□	1.5V
GS2823Z18F	GS2823L18F	CXF□□□	GS2823F18F GS2823F18F1	XF □□	1.8V
GS2823Z25F	GS2823L25F	CXH□□□	GS2823F25F GS2823F25F1	XH □□	2.5V
GS2823Z28F	GS2823L28F	CXJ□□□	GS2823F28F GS2823F28F1	XJ □□	2.8V
GS2823Z29F	GS2823L29F	CXP□□□	GS2823F29F GS2823F29F1	XP □□	2.9V
GS2823Z33F	GS2823L33F	CXR□□□	GS2823F33F GS2823F33F1	XR □□	3.3V
GS2823Z40F	GS2823L40F	CXU□□□	GS2823F40F GS2823F40F1	XU □□	4.0V

GS2823 1 2 2 3 4

Product Name:

GS2823

Package Code:

- 1 is Z, L and F
- Z for SOT-23
 - L for SOT-23-5L
 - F for DFN1x1-4L

Voltage Code:

- 2 2 is 12, 15, 18 and so on.
- 12 for 1.2V, 15 for 1.5V, 18 for 1.8V and so on.

Green Level:

3 is F stands for RoHS Compliant and Halogen Free

Dedicated Code (Only for DFN1x1-4L Package) :

- 4 is Blank or 1
- Blank for 10KPCS/Reel
 - 1 for 3KPCS/Reel

Marking Information

CX 1 2 2 2

X 1
2 2

Product Code:

- CX for SOT-23 and SOT-23-5L package
- X for DFN1x1-4L

Voltage Code:

- 1 is D, G, F and so on.
- D for 1.2V
 - G for 1.5V
 - F for 1.8V
 - H for 2.5V
 - J for 2.8V
 - P for 2.9V
 - R for 3.3V
 - U for 4.0V

GS Code:

- 2 2 2 / 2 2 is GS Code
- 2 2 2 for SOT-23 and SOT-23-5L package
 - 2 2 for DFN1x1-4L

Absolute Maximum Ratings

($T_A=25^{\circ}\text{C}$ unless otherwise specified)

Symbol	Parameter	Value	Units
V_{IN}	Power Supply Voltage	7.0	V
V_{EN}	Enable Voltage	7.0	V
V_{OUT}	Output Voltage	-0.3 to V_{IN}	V
I_{OUT}	Output Current	500	mA
P_D	Total Power Dissipation	SOT-23	560
		SOT-23-5L	600
		DFN1x1-4L	340
T_{STG}	Storage Temperature Range	-55 to +125	$^{\circ}\text{C}$
T_A	Operating Ambient Temperature	-40 to +85	$^{\circ}\text{C}$
T_J	Operating Junction Temperature	+125	$^{\circ}\text{C}$
T_{LEAD}	Lead Temperature(soldering) 5sec.	260	$^{\circ}\text{C}$
$R_{\theta JA}$	Thermal Resistance, Junction to Ambient	SOT-23	179
		SOT-23-5L	166
		DFN1x1-4L	294

Electrical Characteristics

(Unless otherwise specified $V_{IN}=V_{OUT}+1\text{V}$, $T_A=25^{\circ}\text{C}$)

Symbol	Parameter	Test Conditions	Min	Typ	Max	Unit	
I_{SS}	Supply Current	$V_{IN}=V_{OUT}+1.0\text{V}$, En pin=ON, No Load	-	150	-	μA	
$I_{stand-by}$	Standby Current	$V_{IN}=V_{OUT}+1.0\text{V}$, En pin=OFF, No Load	-	0.01	0.4	μA	
V_{IN}	Input Voltage	-	1.6	-	5.5	V	
V_{OUT}	Output Voltage	$V_{IN}=V_{OUT}+1.0\text{V}$ $I_{OUT} = 10\text{mA}$	$V_{OUT}<2.0\text{V}$	$V_{OUT}-0.02$	V_{OUT}	$V_{OUT}+0.02$	V
			$V_{OUT}\geq 2\text{V}$	$V_{OUT}\times 0.99$	V_{OUT}	$V_{OUT}\times 1.01$	
I_{OUTMAX}	Max Output Current	$V_{IN}\geq V_{OUT}+1.0\text{V}$	$1.2\text{V}\leq V_{OUT}\leq 4.0\text{V}$	300	-	-	mA
ΔV_{LINE}	Line regulation	$V_{OUT}+0.5\text{V}\leq V_{IN}\leq 5.5\text{V}$ $I_{OUT} = 50\text{mA}$	$1.2\text{V}\leq V_{OUT}\leq 4.0\text{V}$	-	0.01	0.1	%/V
ΔV_{LOAD}	Load Regulation	$V_{IN}=V_{OUT}+1\text{V}$ $0.1\text{mA}\leq I_{OUT}\leq 300\text{mA}$	$1.2\text{V}\leq V_{OUT}\leq 4.0\text{V}$	-	25	45	mV
V_{DROP}	Dropout Voltage	$I_{OUT} = 300\text{mA}$	$1.2\text{V}\leq V_{OUT}<1.3\text{V}$	-	0.48	0.63	V
			$1.3\text{V}\leq V_{OUT}<1.4\text{V}$	-	0.44	0.58	
			$1.4\text{V}\leq V_{OUT}<1.5\text{V}$	-	0.42	0.52	
			$1.5\text{V}\leq V_{OUT}<1.6\text{V}$	-	0.42	0.46	
			$1.6\text{V}\leq V_{OUT}<1.8\text{V}$	-	0.40	0.44	
			$1.8\text{V}\leq V_{OUT}<2.0\text{V}$	-	0.30	0.41	
			$2.0\text{V}\leq V_{OUT}<2.5\text{V}$	-	0.27	0.38	
			$2.5\text{V}\leq V_{OUT}<3.0\text{V}$	-	0.24	0.35	
$3.0\text{V}<V_{OUT}\leq 4.0\text{V}$	-	0.20	0.31				

$\Delta V_{OUT}/\Delta T$	Output Voltage Temperature Coefficient	$V_{IN}=V_{OUT}+1V$, $I_{OUT}=10mA$, $-40^{\circ}C \leq T_A \leq 85^{\circ}C$	-	± 100	-	ppm/ $^{\circ}C$
PSRR	Power Supply Rejection Ratio	$V_{IN}=V_{OUT}+1V$ $I_{OUT}=30mA$, $f=1KHZ$	-	80	-	dB
$V_{EN}(HI)$	EN Input High Voltage	$V_{IN}=V_{OUT}+1V$	1.0	-	-	V
$V_{EN}(LO)$	EN Input Low Voltage	$V_{IN}=V_{OUT}+1V$	-	-	0.3	V
$I_{EN}(HI)$	EN Input High Current	$V_{IN}=V_{EN}=5.5V$	3.0	5.5	9.0	μA
$I_{EN}(LO)$	EN Input Low Current	$V_{EN}=0V$	-0.1	-	0.1	μA
I_{short}	Short-Circuit Current	$V_{IN}=V_{OUT}+1.0V$, En Pin=ON, $V_{OUT}=0V$	-	50	-	mA
I_{LIM}	Current Limit	$V_{IN}=V_{EN}$	310	400	-	mA
I_{RUSH}	Inrush Current	$V_{IN}=5.5V$, $V_{EN}=0 \sim 5.5V$	-	150	-	mA
R_{DCHG}	On Resistance for Discharge	$V_{IN}=5.5V$, $V_{OUT}=2V$, $V_{EN}=0V$	-	280	-	Ω

Typical Applications

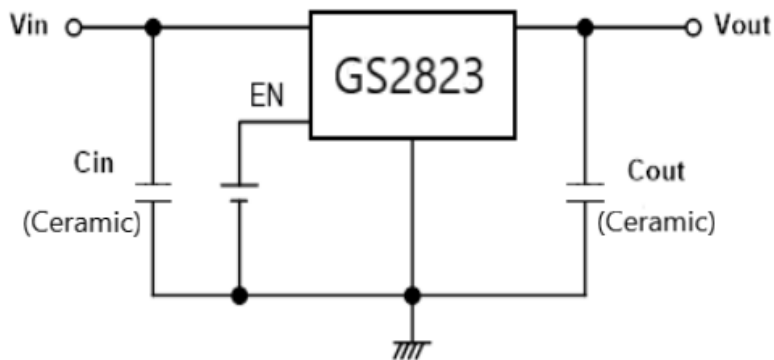

C_{IN} : 1 μF or more. C_{OUT} : 1 μF or more

Test Circuit

Operating Function Test

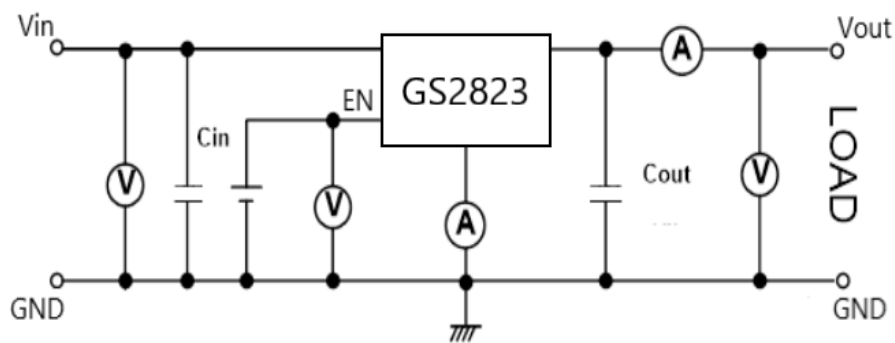

C_{IN} : 1 μF or more. C_{OUT} : 1 μF or more

Enable Function Test

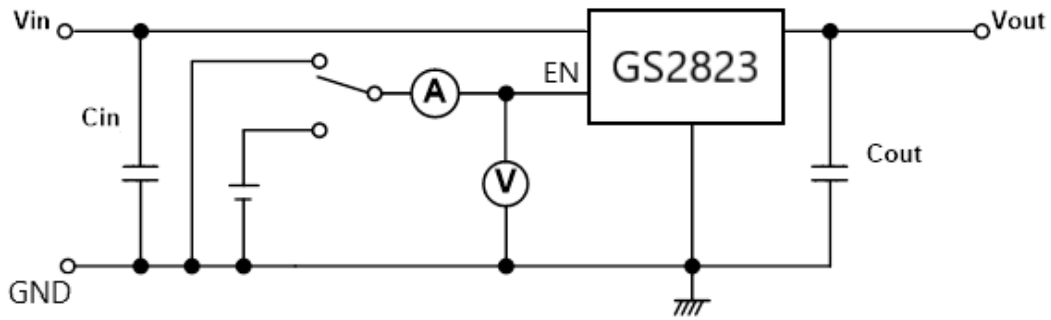

$C_{IN} : 1\mu\text{F}$ or more. $C_{OUT} : 1\mu\text{F}$ or more

Typical Performance Characteristics

Line Transient Response Characteristics

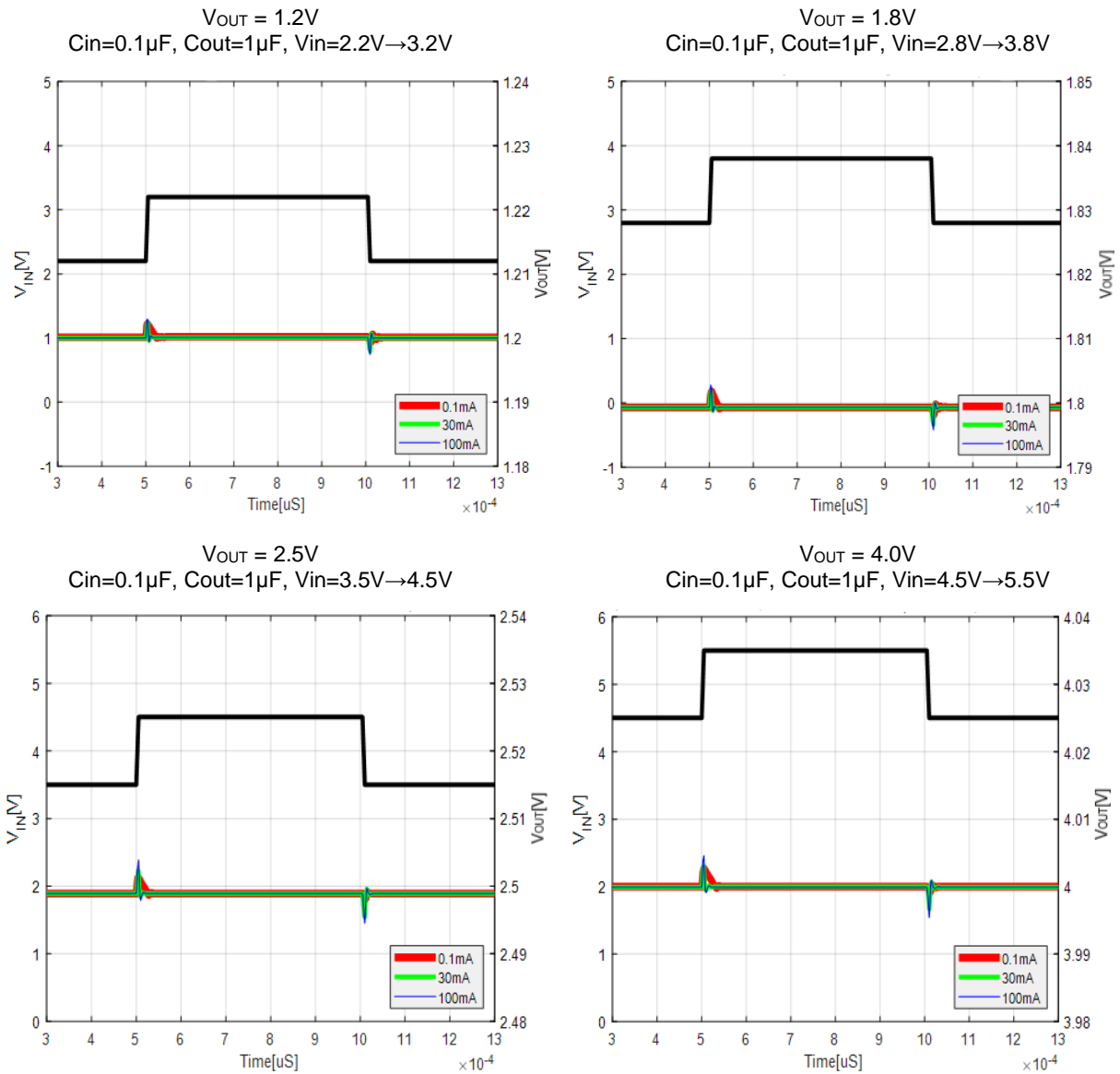

Load Transient Response Characteristics

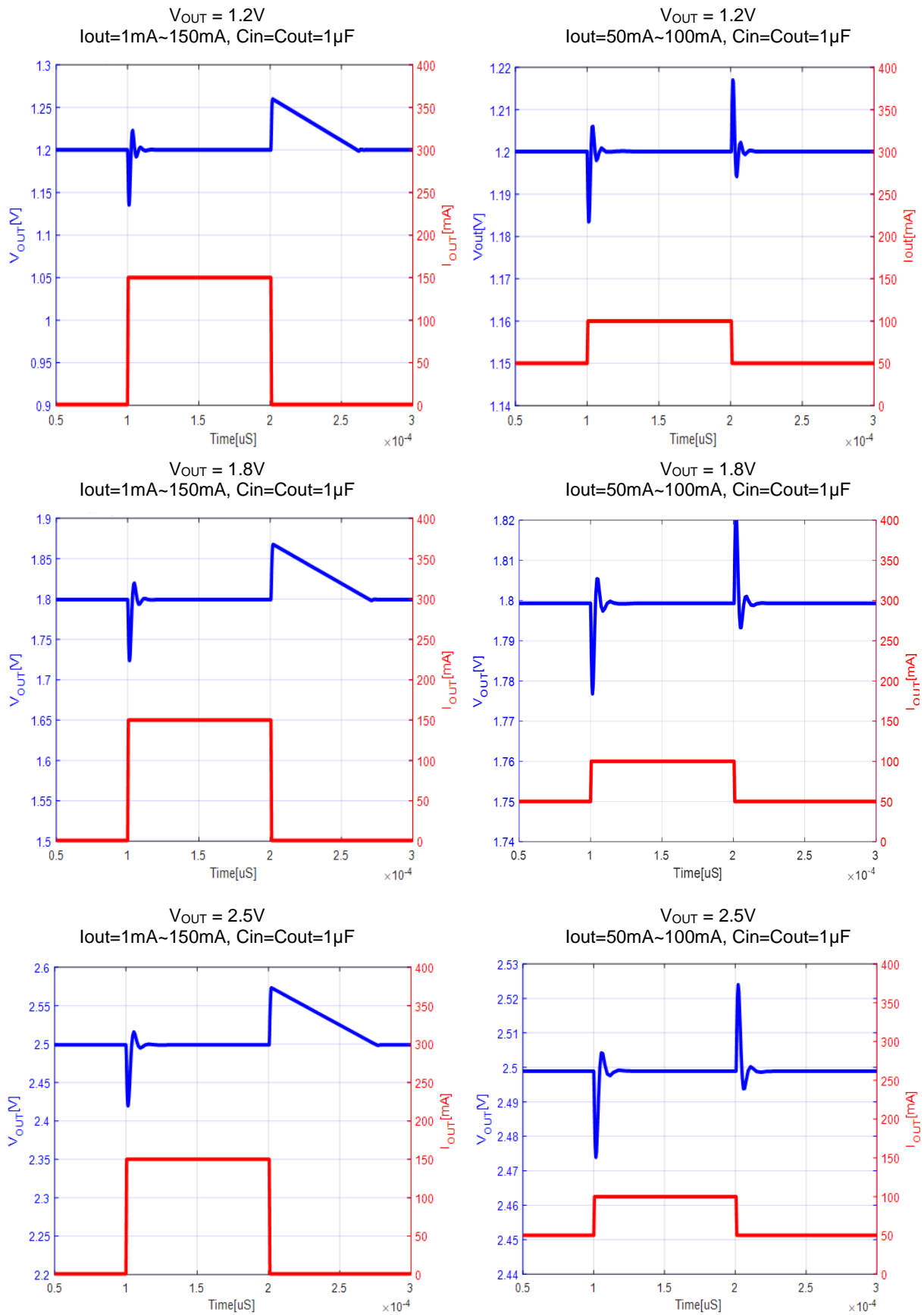

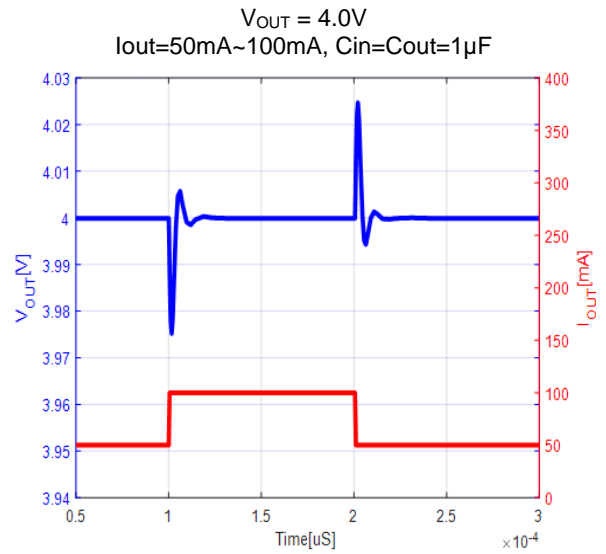
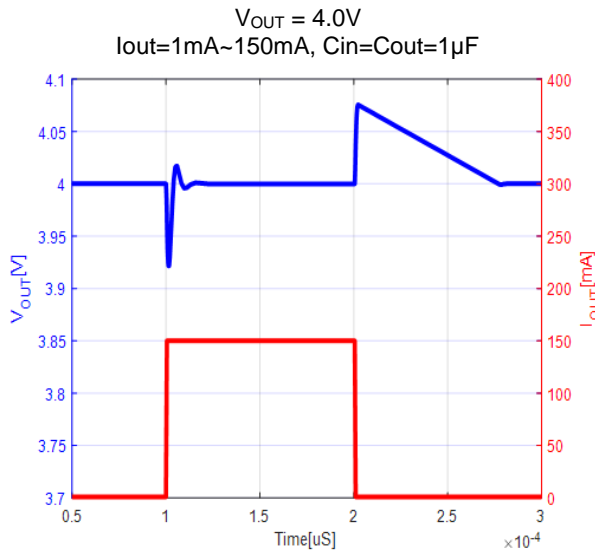

Ripple Rejection

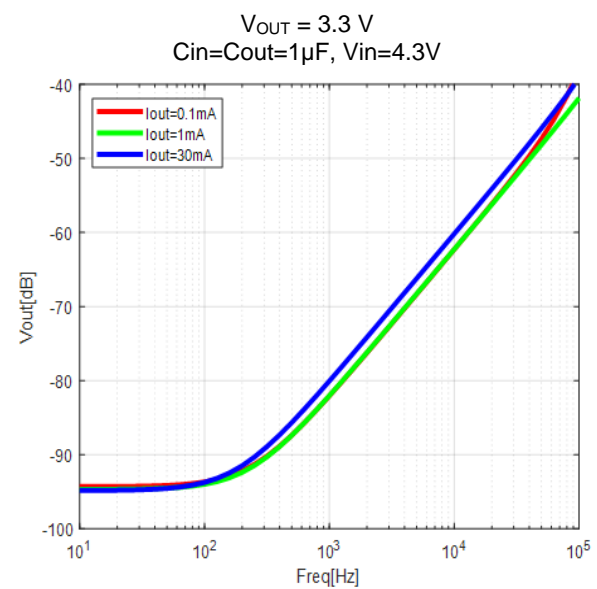
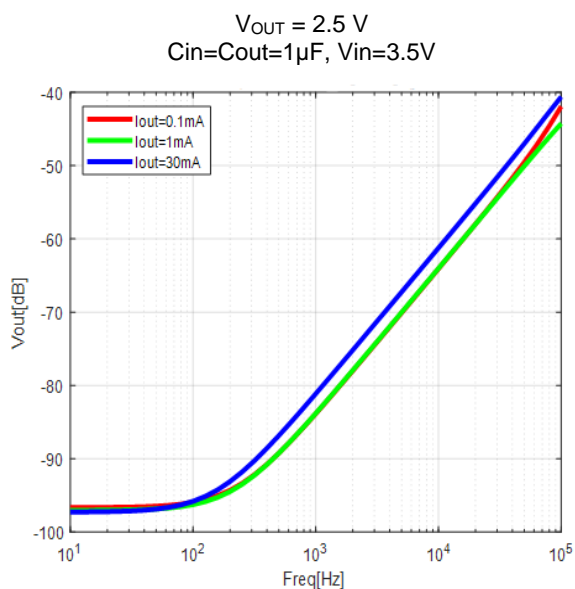
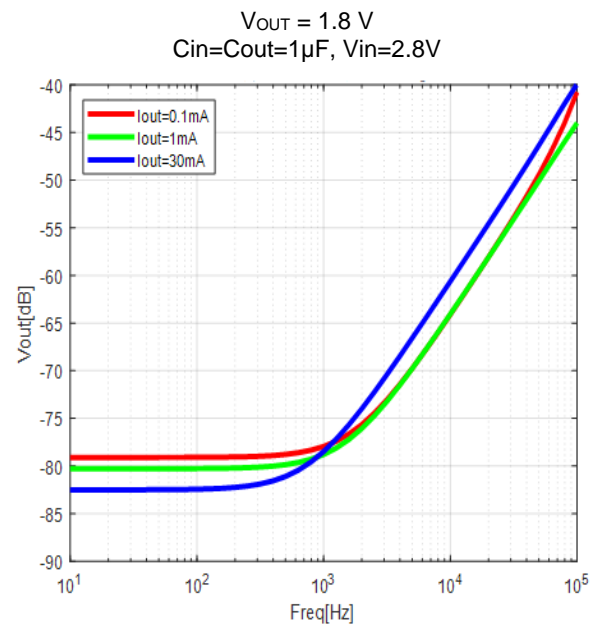
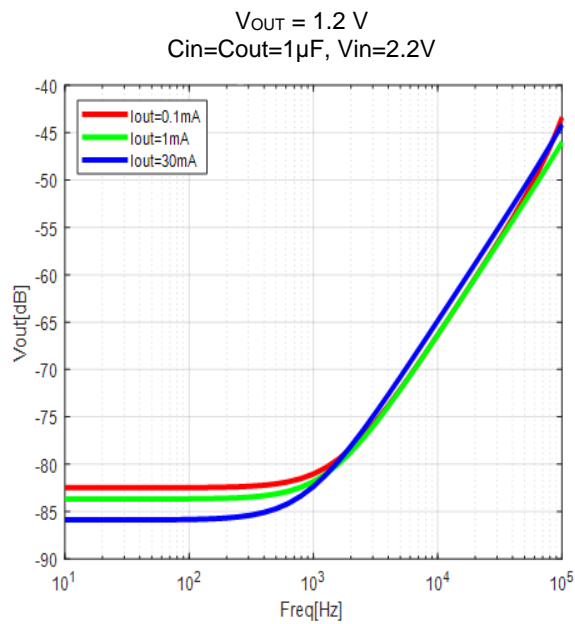

EN Pin Rising Response Characteristics

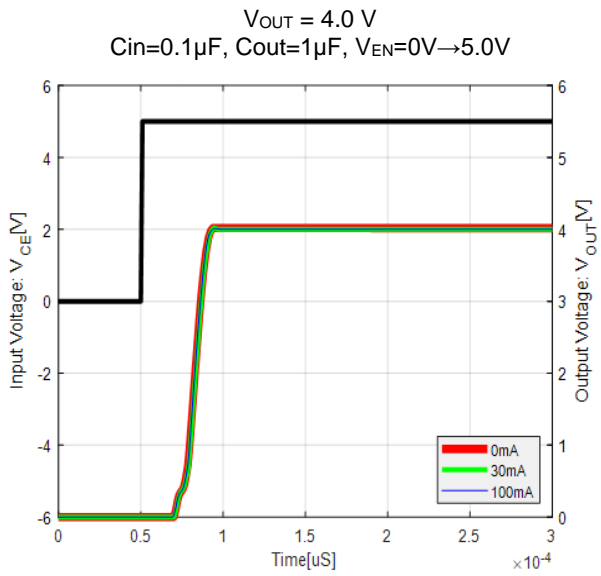
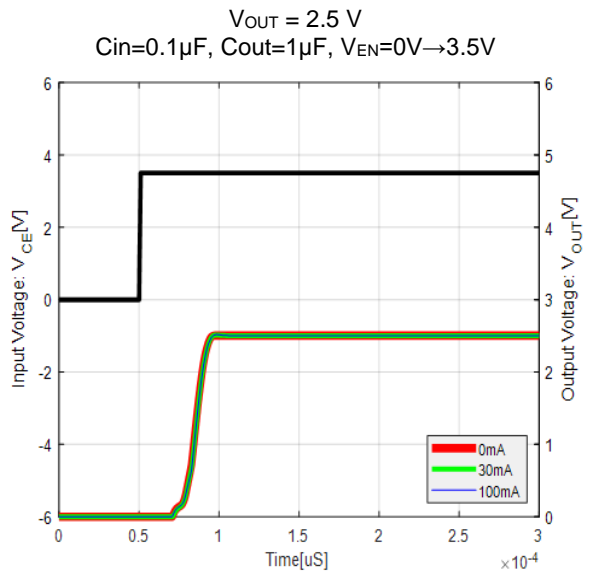
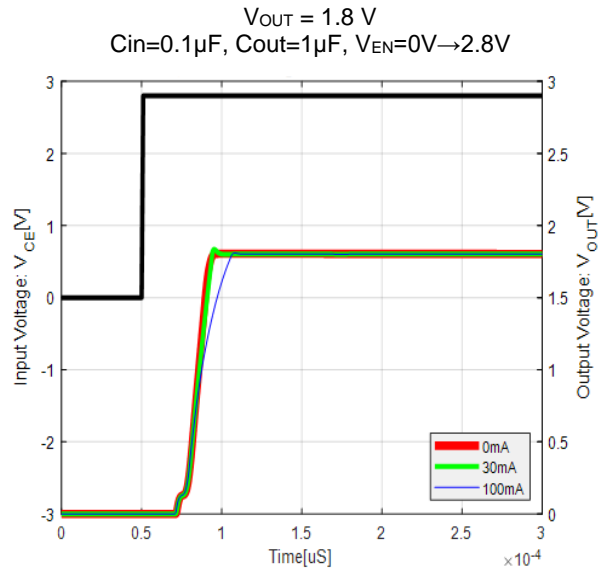
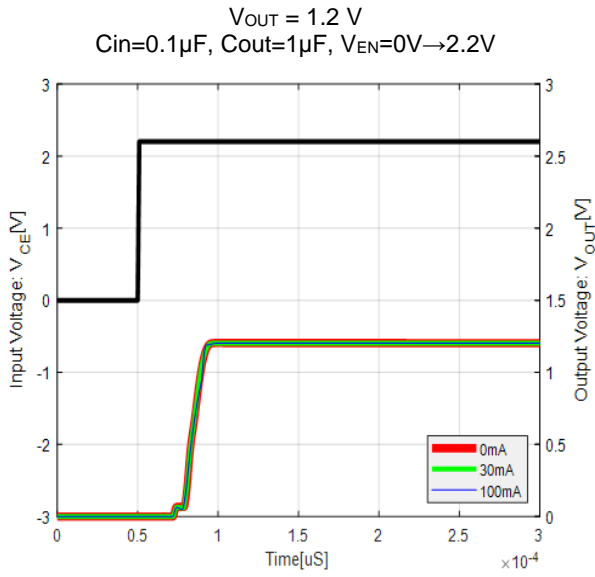

Inrush Current Response Time

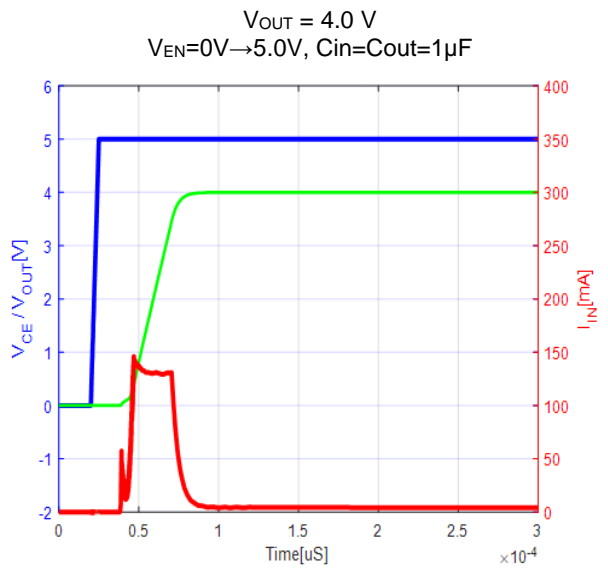
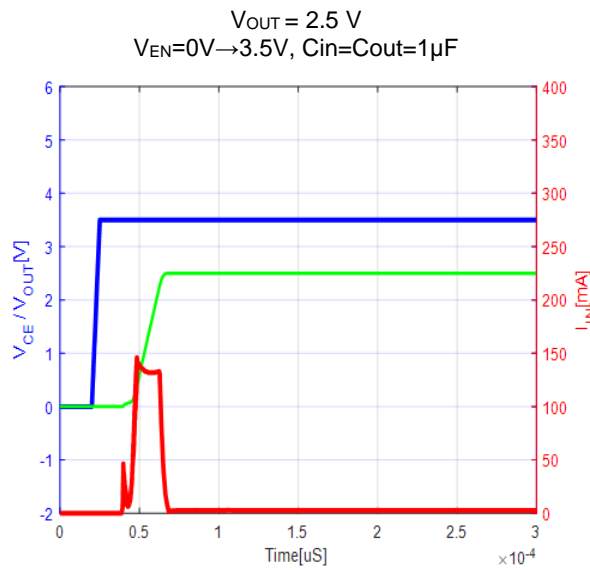
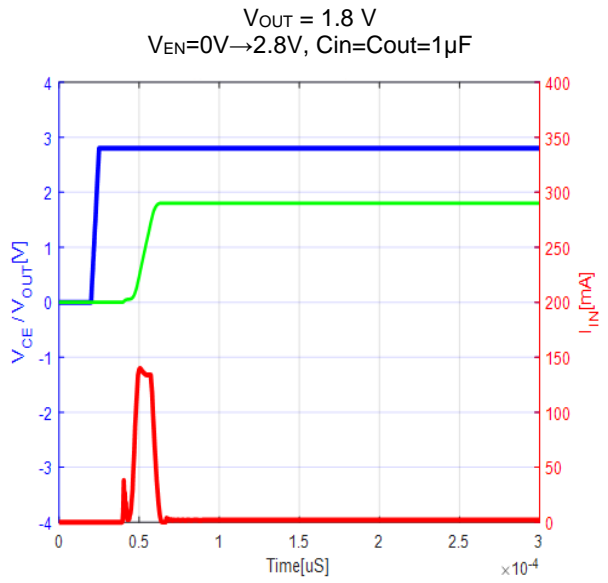
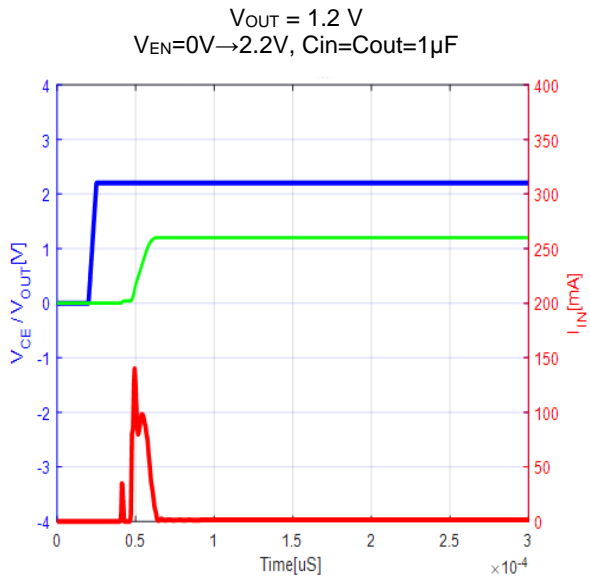

SOT-23

Package Dimension

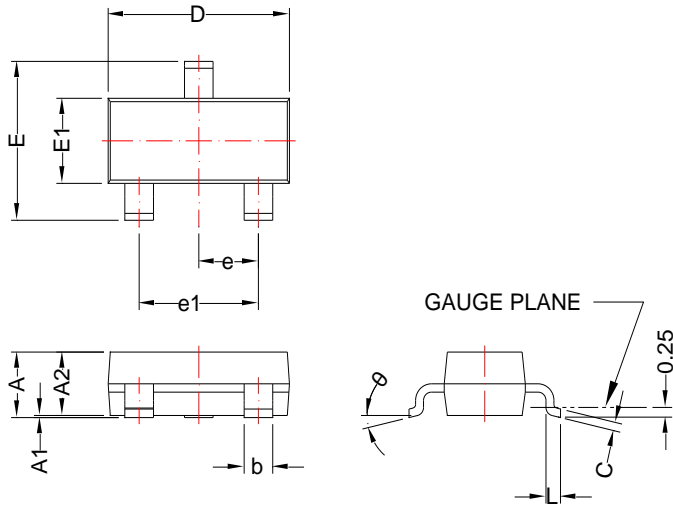

Recommended Land Pattern

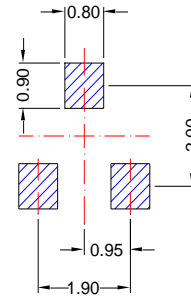

Dimensions				
Symbol	Millimeters		Inches	
	MIN	MAX	MIN	MAX
A	0.75	1.17	0.030	0.046
A1	0.01	0.15	0.000	0.006
A2	0.70	1.02	0.028	0.040
b	0.30	0.50	0.012	0.020
c	0.08	0.20	0.003	0.008
D	2.80	3.04	0.110	0.120
E	2.10	2.64	0.083	0.104
E1	1.20	1.40	0.047	0.055
e	0.95 BSC		0.037 BSC	
e1	1.90 BSC		0.075 BSC	
L	0.30	0.60	0.012	0.024
θ	0°	8°	0°	8°

NOTE:

DIMENSION D and E1 DO NOT INCLUDE MOLD FLASH, PROTRUSIONS OR GATE BURRS. MOLD FLASH, PROTRUSIONS OR GATE BURRS SHALL NOT EXCEED 0.25mm PER END.

SOT-23-5L

Package Dimension

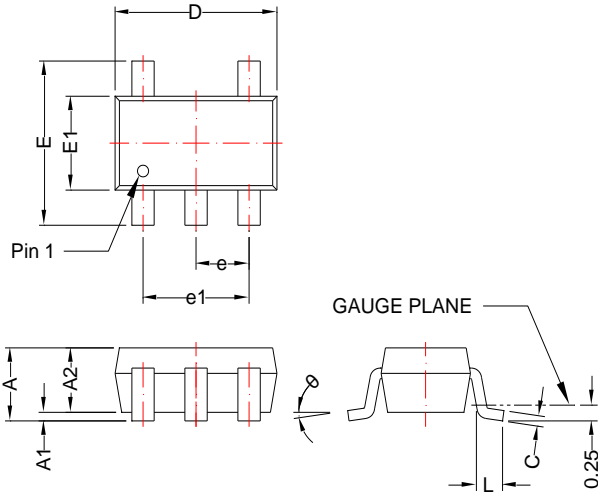

Recommended Land Pattern

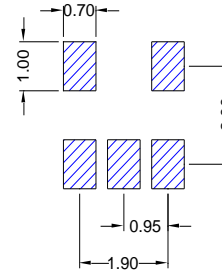

Dimensions				
Symbol	Millimeters		Inches	
	MIN	MAX	MIN	MAX
A	0.90	1.45	0.035	0.057
A1	0.00	0.15	0.000	0.006
A2	0.90	1.30	0.035	0.051
b	0.30	0.50	0.012	0.020
c	0.08	0.26	0.003	0.010
D	2.70	3.10	0.106	0.122
E	2.20	3.00	0.087	0.118
E1	1.30	1.75	0.051	0.069
e	0.95 BSC		0.037 BSC	
e1	1.90 BSC		0.075 BSC	
L	0.30	0.60	0.012	0.024
θ	0°	8°	0°	8°

NOTE:

DIMENSION D and E1 DO NOT INCLUDE MOLD FLASH, PROTRUSIONS OR GATE BURRS. MOLD FLASH, PROTRUSIONS OR GATE BURRS SHALL NOT EXCEED 0.25mm PER END.

DFN1x1-4L

Package Dimension

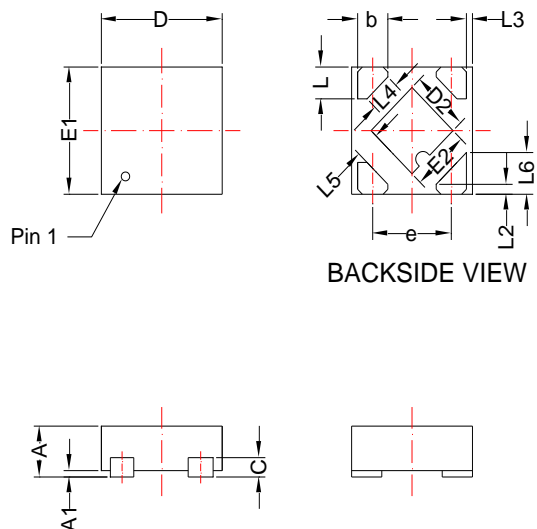

Recommended Land Pattern

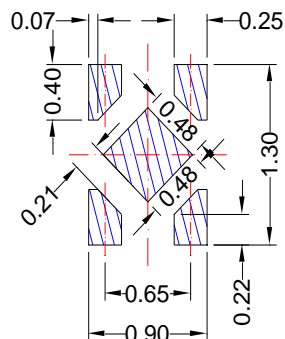

Dimensions				
Symbol	Millimeters		Inches	
	MIN	MAX	MIN	MAX
A	0.35	0.40	0.014	0.016
A1	0.00	0.05	0.000	0.002
b	0.20	0.30	0.008	0.012
c	0.127 REF		0.005 REF	
D	0.95	1.05	0.037	0.041
D2	0.43	0.53	0.017	0.021
E1	0.95	1.05	0.037	0.041
E2	0.43	0.53	0.017	0.021
E	0.65 BSC		0.026 BSC	
L	0.20	0.30	0.008	0.012
L2	0.078 REF		0.003 REF	
L3	0.050 REF		0.002 REF	
L4	0.243 REF		0.010 REF	
L5	0.200 REF		0.008 REF	
L6	0.328 REF		0.013 REF	





NOTE:



DIMENSIONS ARE EXCLUSIVE OF BURRS, MOLD FLASH & TIE BAR EXTRUSIONS.

NOTICE

- Globaltech Semiconductor assumes no responsibility for equipment failures that result from using products at values that exceed, even momentarily, rated values (such as maximum ratings, operating condition ranges, or other parameters) listed in products specifications of any and all Globaltech Semiconductor products described or contained herein. Globaltech Semiconductor products are not designed for use in life support appliances, devices or systems where malfunction of these products can be reasonably expected to result in personal injury. Reproduction in whole or in part is prohibited without the prior written consent of the copyright owner.
- Applications shown on the herein document are examples of standard use and operation. Customers are responsible in comprehending the suitable use in particular applications. Globaltech Semiconductor makes no representation or warranty that such applications will be suitable for the specified use without further testing or modification.
- Information furnished is believed to be accurate and reliable. However Globaltech Semiconductor assumes no responsibility for the consequences of use of such information nor for any infringement of patents or other rights of third parties, which may result from its use. No license is granted by implication or otherwise under any patent or patent rights of Globaltech Semiconductor. Specifications mentioned in this publication are subject to change without notice. This publication supersedes and replaces all information without express written approval of Globaltech Semiconductor.

CONTACT US

GS Headquarter	
	4F.,No.43-1,Lane11,Sec.6,Minquan E.Rd Neihu District Taipei City 114, Taiwan (R.O.C)
	886-2-2657-9980
	886-2-2657-3630
	sales_twn@gs-power.com

RD Division	
	824 Bolton Drive Milpitas. CA. 95035
	1-408-457-0587