

GS2515 Series

40V Low-Power LDO Regulator

General Description

The GS2515 is a 40V low-power high accuracy LDO regulator. The 2.5 μ A power consumption makes it ideal for most HV power-saving systems. The maximum operating voltage can be as high as 40V. The output accuracy is as excellent as $\pm 1.0\%$.

The other features include low dropout voltage, current limiting protection and thermal shutdown protection.

The GS2515 is available in SOT-23-5L, SOT-23-3L, SOT-89-3L packages.

Features

- Maximum Operating Voltage: 40V
- Output Voltage: 1.8V ~ 5.0V
- Output Accuracy: $\pm 1.0\%$
- Low Power Consumption: 2.5 μ A Typical
- < 0.2 μ A Standby Current
- Current Limiting, Thermal Shutdown
- Available in SOT-23-5L, SOT-23-3L and SOT-89-3L Packages
- RoHS Compliant and Halogen Free

Applications

- Battery Supplied Systems
- Telecom Systems
- Audio & Video Devices

Function Block Diagram

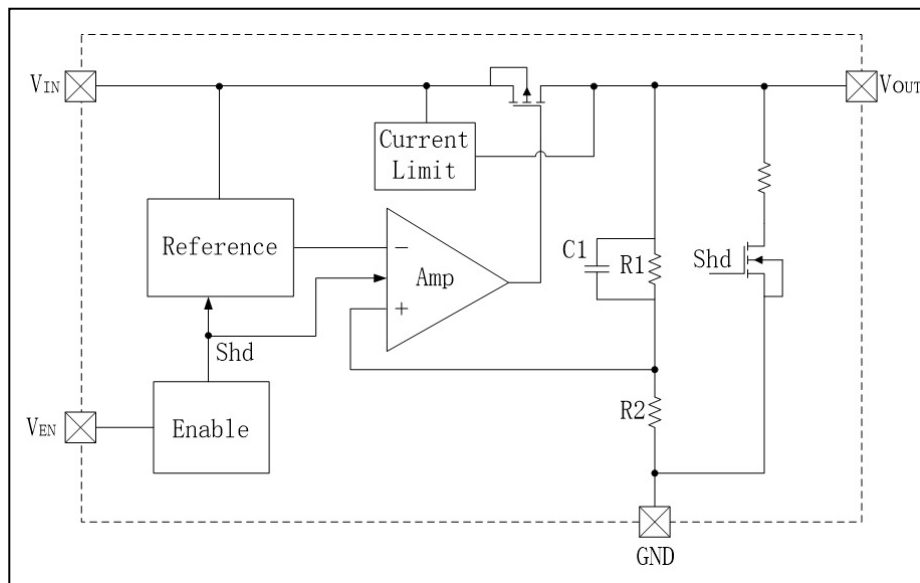

Packages & Pin Assignments

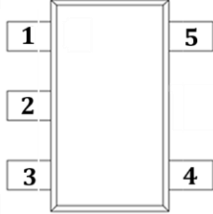
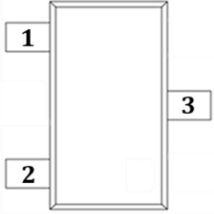
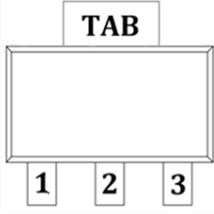
SOT-23-5L		SOT-23-3L		SOT-89-3L	
					
Pin No.	Symbol	Pin No.	Symbol	Pin No.	Symbol
1	V_{IN}	1	GND	1	GND
2	GND	2	V_{OUT}	2, TAB	V_{IN}
3	EN	3	V_{IN}	3	V_{OUT}
4	NC				
5	V_{OUT}				
Symbo		Description			
V_{IN}		Power Supply Input			
V_{OUT}		Output Pin			
GND		Ground Pin			
EN		Chip Enable w/ High Voltage			
NC		Not Connect			

Ordering and Marking Information

Ordering Information				
SOT-23-5L	SOT-23-3L	SOT-89-3L	Marking	Output Voltage
GS2515L18F	GS2515JL18F	-	LW6518 □□□□□	1.8V
GS2515L25F	GS2515JL25F	GS2515Y25F	LW6525 □□□□□	2.5V
GS2515L30F	GS2515JL30F	GS2515Y30F	LW6530 □□□□□	3.0V
GS2515L33F	GS2515JL33F	GS2515Y33F	LW6533 □□□□□	3.3V
GS2515L50F	GS2515JL50F	GS2515Y50F	LW6550 □□□□□	5.0V

GS2515¹²³⁴⁵

Product Code:

GS2515

Package Code:

- ¹ ² is L, JL and Y
- L is SOT-23-5L
 - JL is SOT-23-3L
 - Y is SOT-89-3L

Voltage Code:

- ³ ⁴ is 18, 25, 30 and so on.
- 18 for 1.8V, 25 for 2.5V, 30 for 3.0V and so on.

Green Level:

⁵ is F stands for RoHS Compliant and Halogen Free

Marking Information

LW65¹¹
²²²²²

Product Code:

- LW65

Voltage Code:

- ¹¹ is 18, 25, 30 and so on.
- 18 for 1.8V
 - 25 for 2.5V
 - 30 for 3.0V
 - 33 for 3.3V
 - 50 for 5.0V

GS Code:

²²²²² is GS Code

Absolute Maximum Ratings ¹

T_A=25°C, unless otherwise specified

Symbol	Parameter	Rating	Units	
V _{IN}	Supply Voltage	-0.3~44	V	
V _{EN}	EN pin to GND Voltage	-0.3~44	V	
V _{OUT}	V _{OUT} pin to GND Voltage	-0.3~6.0	V	
P _D	Maximum Power Dissipation ²	SOT-23-5L	0.5	W
		SOT-23-3L		
		SOT-89-3L	1.0	
R _{θJA}	Thermal Resistance, Junction to Ambient ²	SOT-23-5L	250	°C/W
		SOT-23-3L		
		SOT-89-3L	125	
T _J	Operating Junction Temperature	-40 ~ 150	°C	
T _{STG}	Storage Temperature Range	-40 ~ 150	°C	
T _{LEAD}	Lead Temperature (Soldering 10sec)	260	°C	

NOTE:

- Stresses beyond those listed under Absolute Maximum Ratings may cause permanent damage to the device. These are stress ratings only, and functional operation of the device at these or any other conditions beyond those indicated under Recommended Operating Conditions is not implied. Exposure to absolute-maximum-rated conditions for extended periods may affect device reliability.
- Device mounted on FR-4 PCB.

Recommended Operating Range

Symbol	Parameter	Value	Units
V _{IN}	V _{IN} Supply Voltage	2.5 ~ 40	V
V _{EN}	EN Pin Voltage	0 ~ 40	V
V _{OUT}	V _{OUT} Pin Voltage	1.5 ~ 5.0	V
I _{OUT}	Output Current	0 ~ 150	mA
T _J	Junction Temperature Range	-40 ~ 125	°C

Electrical Characteristics

$V_{IN}=V_{OUT}+1V$, $V_{OUT}=3.3V$, $C_{IN}=C_{OUT}=1\mu F$, $T_A=25^\circ C$, unless otherwise specified.

Symbol	Parameter	Test Conditions	Min.	Typ.	Max.	Units	
V_{IN}	Input Voltage	-	2.5	-	40	V	
V_{OUT}	Output Accuracy	$I_{OUT}=1mA$	-1.0	-	+1.0	%	
I_{LIM}	Current Limit	$V_{IN}=4.3V$, $V_{OUT}=3.3V$	150	210	-	mA	
I_Q	Quiescent Current	$V_{IN}=V_{EN}=V_{OUT}+1V$, No Load	$V_{OUT}<1.8V$	-	3.0	4.0	μA
			$V_{OUT}\geq 1.8V$	-	2.5	3.5	
I_{SHD}	Shutdown Current	$V_{IN}=12V$, $V_{EN}=0V$	-	0.1	0.2	μA	
V_{DROP}	Dropout Voltage ³	$I_{OUT}=100mA$, $V_{OUT}=1.8V$	-	700	-	mV	
		$I_{OUT}=100mA$, $V_{OUT}=3.3V$	-	450	-		
		$I_{OUT}=100mA$, $V_{OUT}=5.0V$	-	360	-		
S_{LINE}	Line Regulation	$V_{IN}=V_{OUT}+1V$ to 40V, $I_{OUT}=1mA$	-	0.02	0.05	%/V	
S_{LOAD}	Load Regulation	$1mA \leq I_{OUT} \leq 150mA$	-	0.005	0.01	%/mA	
I_{SHORT}	Short Current	$V_{OUT}=0V$	-	15	-	mA	
V_{ENH}	EN High Voltage	$V_{IN}=2.5V$ to 40V, $I_{OUT}=1mA$	1.5	-	-	V	
V_{ENL}	EN Low Voltage		-	-	0.5	V	
PSRR	Power Supply Rejection Ratio	$V_{IN}=5.0V$, $C_{IN}=None$, $I_{OUT}=10mA$	$f=217Hz$	-	86	-	dB
			$f=1KHz$	-	81	-	
			$f=10KHz$	-	64	-	
			$f=100KHz$	-	40	-	
T_{SD}	Overheat Protection	Temperature rising	-	165	-	$^\circ C$	
ΔT_{SD}	TSD Hysteresis	Temperature falling	-	15	-	$^\circ C$	
R_{DSCHG}	R_{ON} of V_{OUT} Discharge MOSFET	$V_{IN}=12V$, $V_{OUT}=5.0V$, $V_{EN}=0V$	-	130	-	Ω	

NOTE:

3. The dropout voltage is defined as $V_{IN} - V_{OUT}$, when $V_{OUT} = 95\% \times V_{OUT(NOM)}$

Typical Performance Characteristics

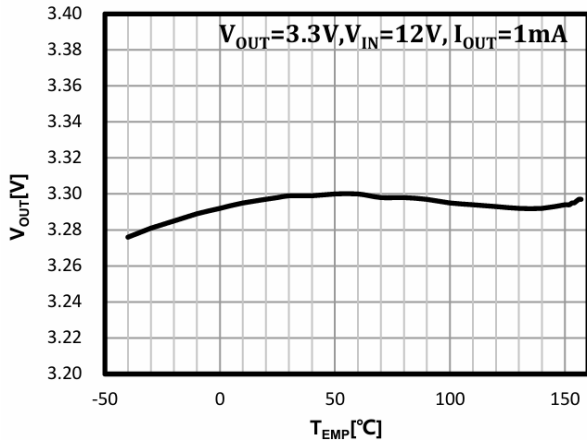

Figure 1. V_{OUT} vs Temperature

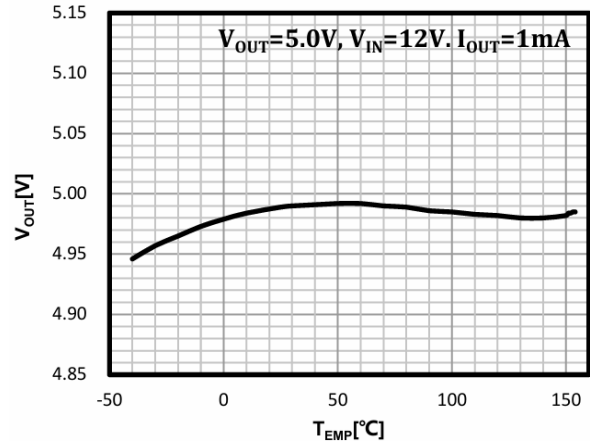

Figure 2. V_{OUT} vs Temperature

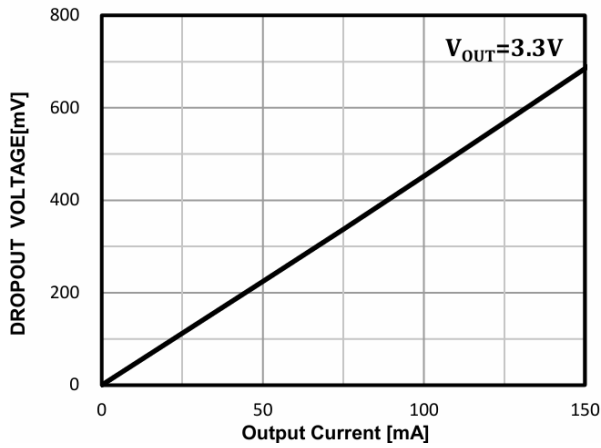

Figure 3. Dropout Voltage vs Output Current

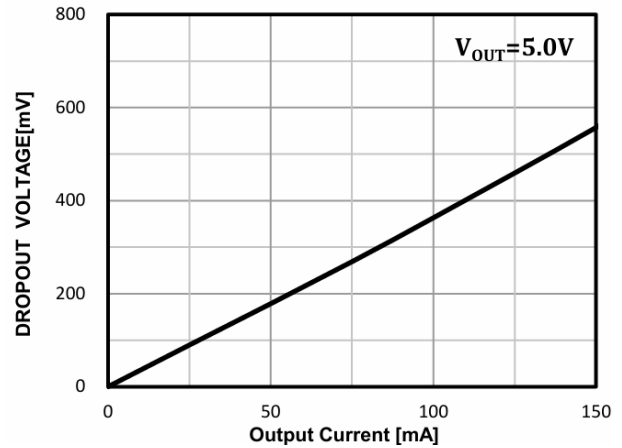

Figure 4. Dropout Voltage vs Output Current

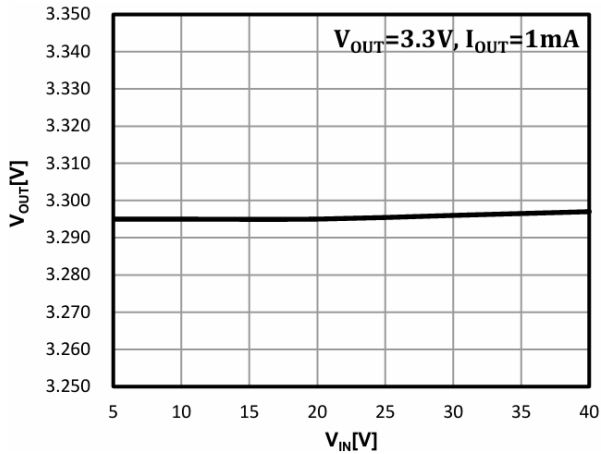

Figure 5. Line Regulation vs V_{IN}

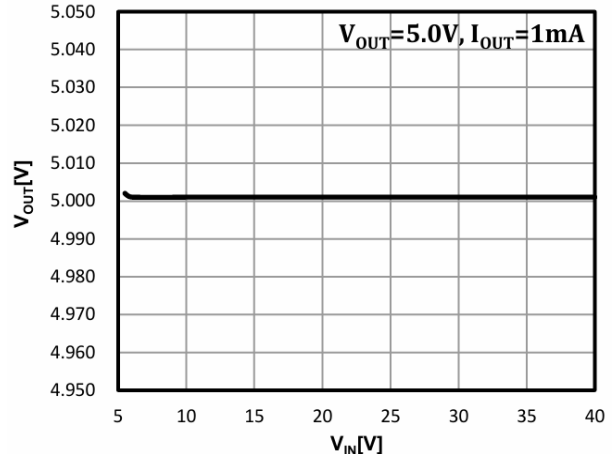

Figure 6. Line Regulation vs V_{IN}

Typical Performance Characteristics

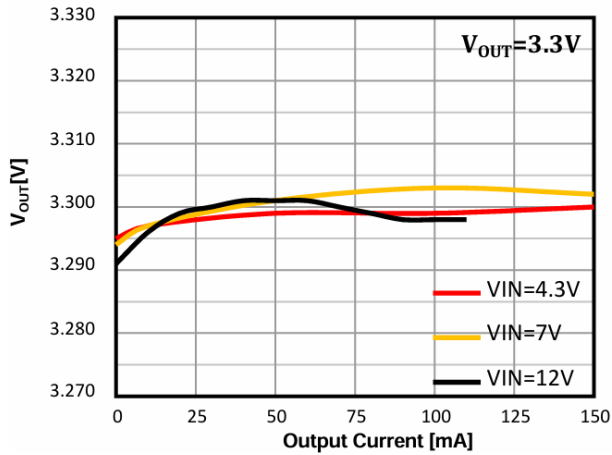

Figure 7. Load Regulation vs Output Current

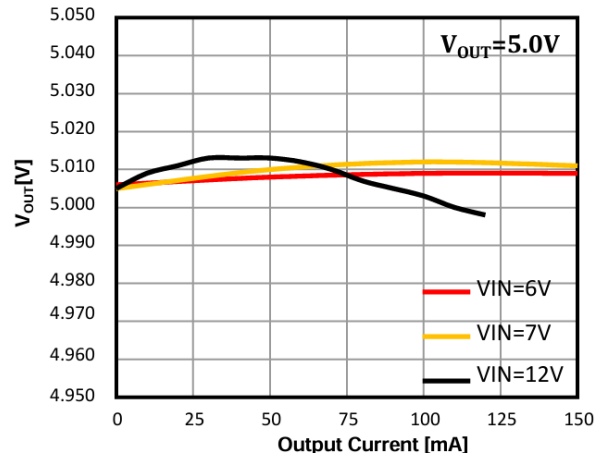
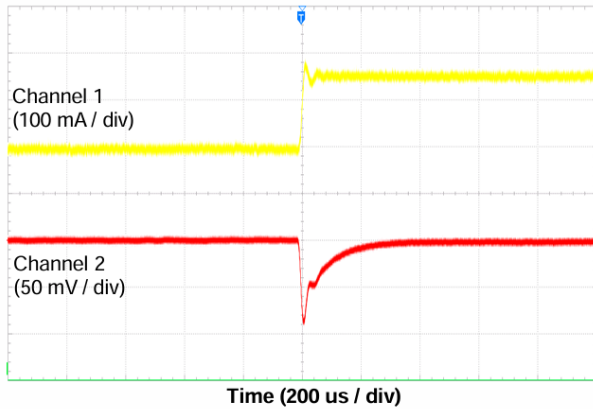
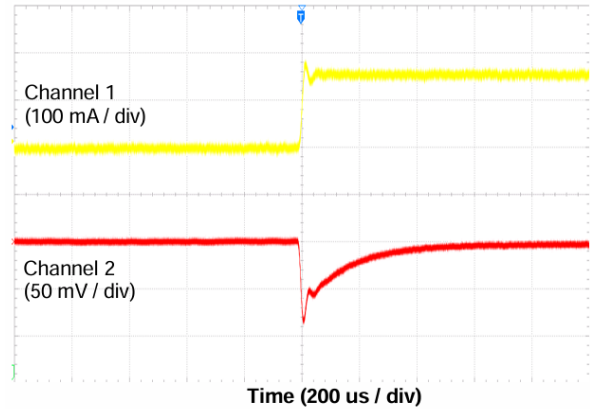

Figure 8. Load Regulation vs Output Current



Channel 1 = I_{OUT} , channel 2 = V_{OUT} , $V_{IN}=4.3V$, $V_{OUT}=3.3V$

Figure 9. Load Transient (1 mA to 150 mA)



Channel 1 = I_{OUT} , channel 2 = V_{OUT} , $V_{IN}=6.0V$, $V_{OUT}=5.0V$

Figure 10. Load Transient (1 mA to 150 mA)

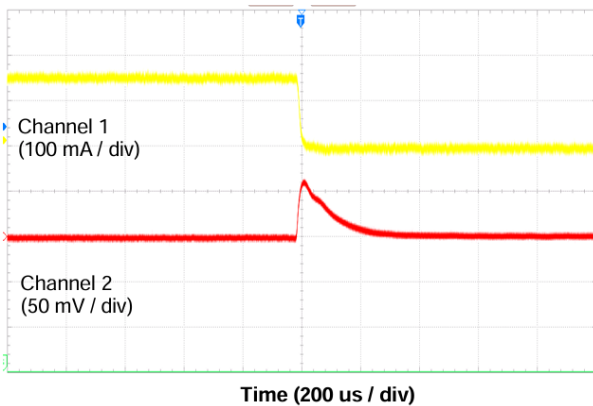

Channel 1 = I_{OUT} , channel 2 = V_{OUT} , $V_{IN}=4.3V$, $V_{OUT}=3.3V$

Figure 11. Load Transient (150 mA to 1 mA)

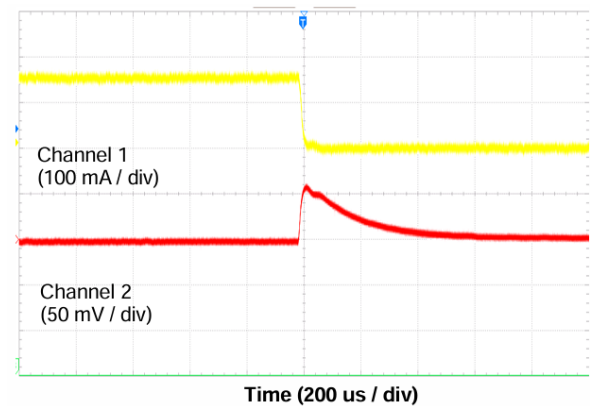

Channel 1 = I_{OUT} , channel 2 = V_{OUT} , $V_{IN}=6.0V$, $V_{OUT}=5.0V$

Figure 12. Load Transient (150 mA to 1 mA)

Typical Performance Characteristics

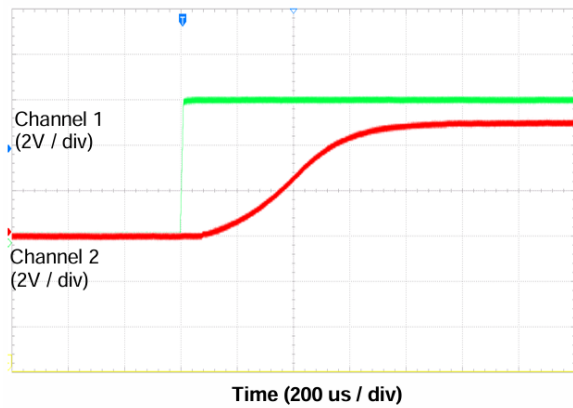

Channel 1 = En, channel 2 = V_{OUT} , $V_{IN}=6.0V$, $V_{OUT}=5.0V$, $I_{OUT}=10mA$

Figure 13. Power-Up with Enable

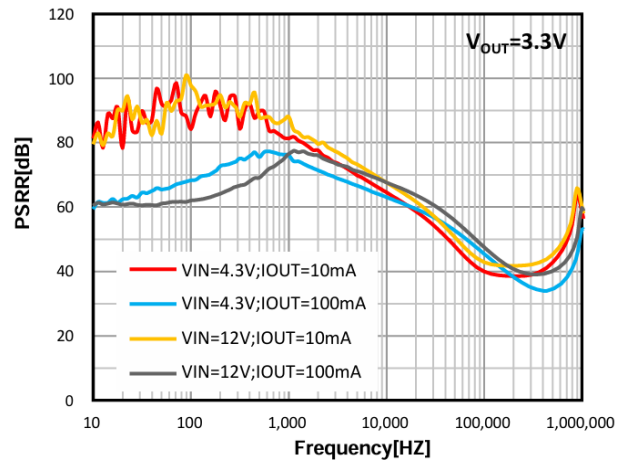
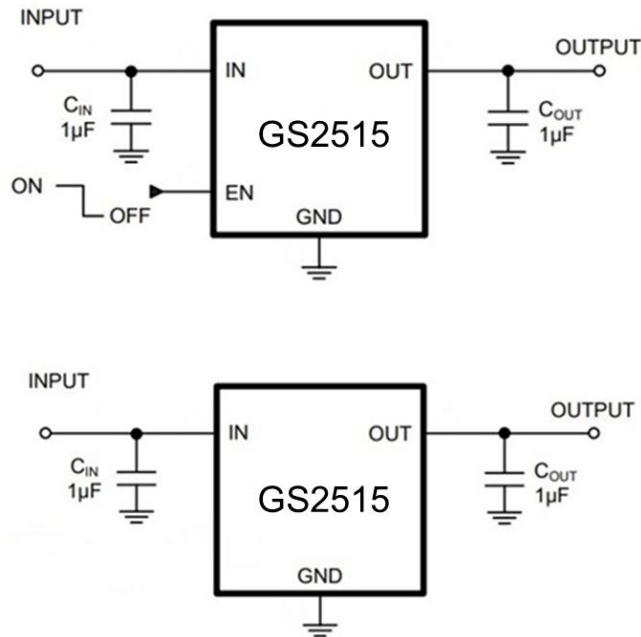

Figure 14. PSRR vs Frequency

Typical Application Circuit



SOT-23-5L

Package Dimension

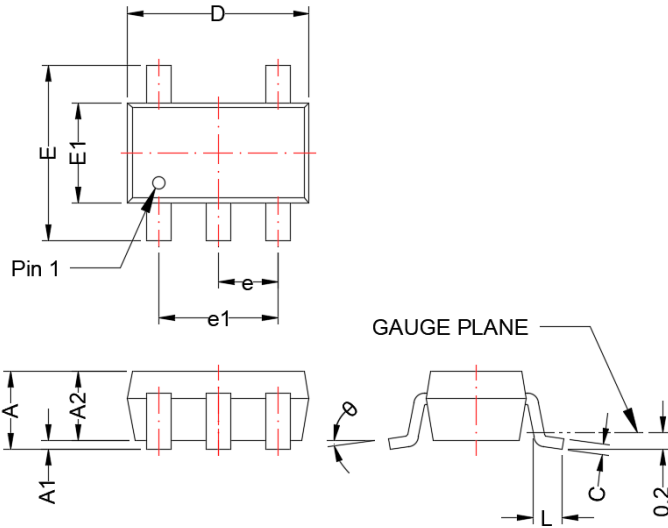

Recommended Land Pattern

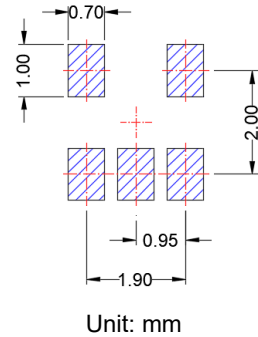

Dimensions				
Symbol	Millimeters		Inches	
	MIN	MAX	Min	MIN
A	0.90	1.45	0.035	0.057
A1	0.00	0.15	0.000	0.006
A2	0.90	1.30	0.035	0.051
b	0.30	0.50	0.012	0.020
c	0.08	0.26	0.003	0.010
D	2.70	3.10	0.106	0.122
E	2.20	3.00	0.087	0.118
E1	1.30	1.75	0.051	0.069
e	0.95 BSC		0.037 BSC	
e1	1.90 BSC		0.075 BSC	
L	0.3	0.6	0.012	0.024
θ	0°	8°	0°	8°

NOTE:
Dimensions are exclusive of Burrs, Mold Flash & Tie Bar extrusions.

SOT-23-3L

Package Dimension

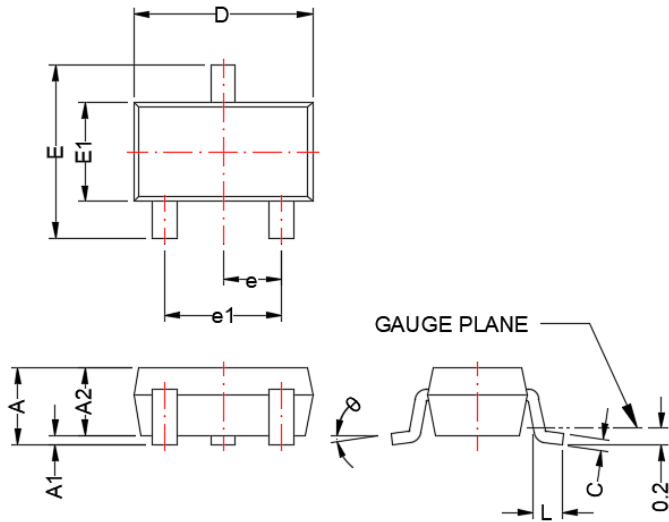

Recommended Land Pattern

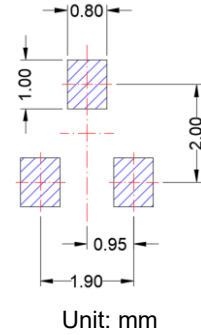

Dimensions

Symbol	Millimeters		Inches	
	MIN	MAX	Min	MIN
A	0.90	1.45	0.035	0.057
A1	0.00	0.15	0.000	0.006
A2	0.90	1.30	0.035	0.051
b	0.30	0.50	0.012	0.020
c	0.08	0.26	0.003	0.010
D	2.70	3.10	0.106	0.122
E	2.20	3.00	0.087	0.118
E1	1.30	1.75	0.051	0.069
e	0.95 BSC		0.037 BSC	
e1	1.90 BSC		0.075 BSC	
L	0.3	0.6	0.012	0.024
θ	0°	8°	0°	8°

NOTE:

Dimensions are exclusive of Burrs, Mold Flash & Tie Bar extrusions.

SOT-89-3L

Package Dimension

Recommended Land Pattern

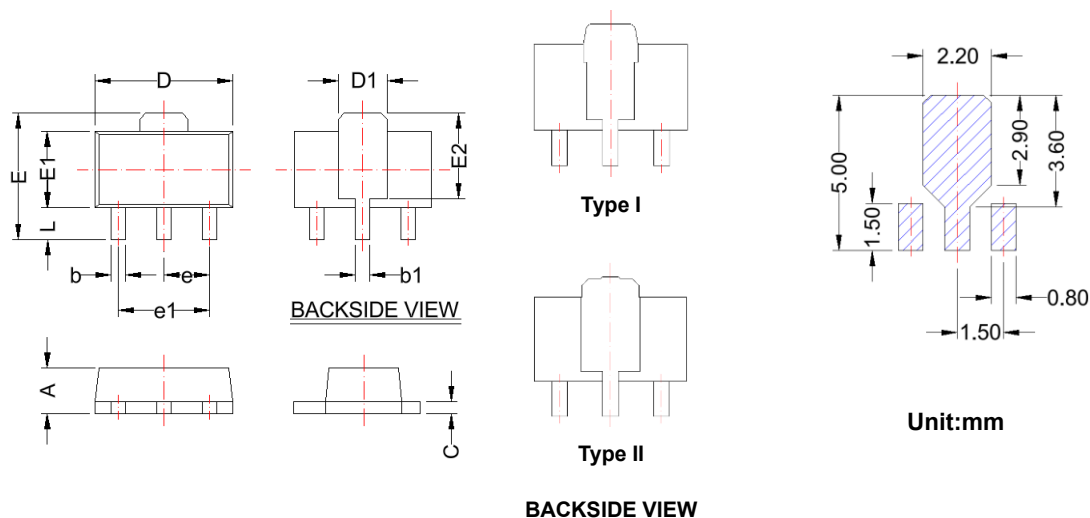





Dimensions				
SYMBOL	Millimeters		Inches	
	MIN	MAX	MIN	MAX
A	1.40	1.60	0.055	0.063
b	0.30	0.55	0.012	0.022
b1	0.40	0.60	0.016	0.024
c	0.35	0.44	0.014	0.017
D	4.40	4.60	0.173	0.181
D1	1.75 REF		0.069 REF	
E	3.90	4.30	0.154	0.169
E1	2.30	2.60	0.091	0.102
E2	2.84 REF		0.112 REF	
e	1.50 BSC		0.059 BSC	
e1	3.00 BSC		0.118 BSC	
L	0.89	1.20	0.035	0.047



NOTE:
Dimensions are exclusive of Burrs, Mold Flash & Tie Bar extrusions.

NOTICE

- Globaltech Semiconductor assumes no responsibility for equipment failures that result from using products at values that exceed, even momentarily, rated values (such as maximum ratings, operating condition ranges, or other parameters) listed in products specifications of any and all Globaltech Semiconductor products described or contained herein. Globaltech Semiconductor products are not designed for use in life support appliances, devices or systems where malfunction of these products can be reasonably expected to result in personal injury. Reproduction in whole or in part is prohibited without the prior written consent of the copyright owner.
- Applications shown on the herein document are examples of standard use and operation. Customers are responsible in comprehending the suitable use in particular applications. Globaltech Semiconductor makes no representation or warranty that such applications will be suitable for the specified use without further testing or modification.
- Information furnished is believed to be accurate and reliable. However, Globaltech Semiconductor assumes no responsibility for the consequences of use of such information nor for any infringement of patents or other rights of third parties, which may result from its use. No license is granted by implication or otherwise under any patent or patent rights of Globaltech Semiconductor. Specifications mentioned in this publication are subject to change without notice. This publication supersedes and replaces all information without express written approval of Globaltech Semiconductor.

CONTACT US

GS Headquarter	
	4F.,No.43-1,Lane11,Sec.6,Minquan E.Rd NeiHu District Taipei City 114, Taiwan (R.O.C)
	886-2-2657-9980
	886-2-2657-3630
	sales_twn@gs-power.com

RD Division	
	824 Bolton Drive Milpitas. CA. 95035
	1-408-457-0587