

# GSMDS6906

## 60V N-Channel MOSFETs

### Product Description

These N-Channel enhancement mode power field effect transistors are using trench DMOS technology. This advanced technology has been especially tailored to minimize on-state resistance, provide superior switching performance, and withstand high energy pulse in the avalanche and commutation mode.

These devices are well suited for high efficiency fast switching applications.

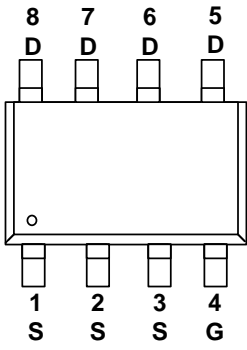
### Features

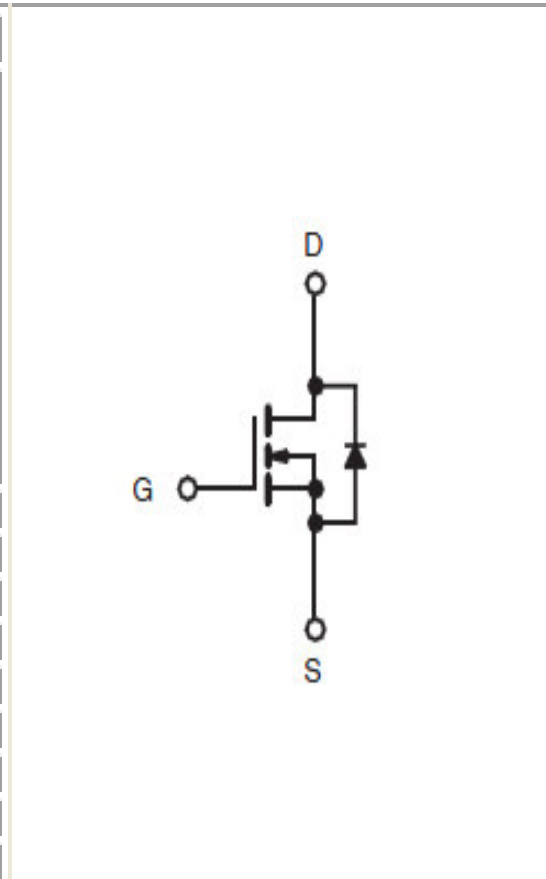
- 60V, 6A,  $R_{DS(ON)}=21m\Omega@V_{GS}=10V$
- Improved dv/dt capability
- Fast switching
- 100% EAS Guaranteed
- Green Device Available
- SOP-8 package design

### Applications

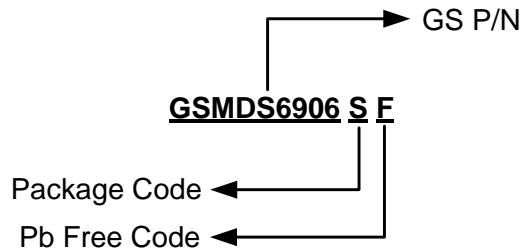
- Motor Drive
- Power Tools
- LED Lighting

### Packages & Pin Assignments

GSMDS6906SF (SOP-8)	
 <p style="text-align: center;">Top View</p>	
Pin	Description
1	Source
2	Source
3	Source
4	Gate
5	Drain
6	Drain
7	Drain
8	Drain

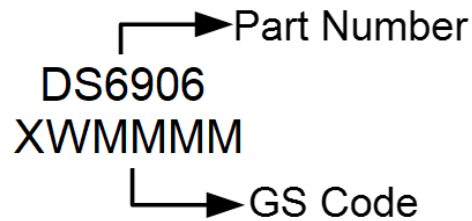


## Ordering Information



Part Number	Package	Quantity Reel
GSMDS6906SF	SOP-8	4000 PCS

## Marking Information



## Absolute Maximum Ratings

$T_C=25^{\circ}\text{C}$  Unless otherwise noted

Symbol	Parameter	Typical	Unit
$V_{DS}$	Drain-Source Voltage	60	V
$V_{GS}$	Gate-Source Voltage	$\pm 20$	V
$I_D$	Continuous Drain Current	$T_C=25^{\circ}\text{C}$	6
		$T_C=100^{\circ}\text{C}$	3.6
$I_{DM}$	Pulsed Drain Current (*1)	24	A
EAS	Single Pulse Avalanche Energy (*2)	42	mJ
IAS	Single Pulse Avalanche Current	29	A
$P_D$	Power Dissipation ( $T_C=25^{\circ}\text{C}$ )	1.47	W
	Power Dissipation (Derate above $25^{\circ}\text{C}$ )	0.0117	W/ $^{\circ}\text{C}$
$T_J$	Operating Junction Temperature Range	-50 to +150	$^{\circ}\text{C}$
$T_{STG}$	Storage Temperature Range	-50 to +150	$^{\circ}\text{C}$
$R_{\theta JA}$	Thermal Resistance-Junction to Ambient	85	$^{\circ}\text{C}/\text{W}$
$R_{\theta JC}$	Thermal Resistance-Junction to Case	23	$^{\circ}\text{C}/\text{W}$

Note 1: Repetitive Rating: Pulsed width limited by maximum junction temperature.

Note 2:  $V_{DD}=25\text{V}$ ,  $V_{GS}=10\text{V}$ ,  $L=0.1\text{mH}$ ,  $I_{AS}=29\text{A}$ ,  $R_G=25\Omega$ , Starting  $T_J=25^{\circ}\text{C}$ .

## Electrical Characteristics

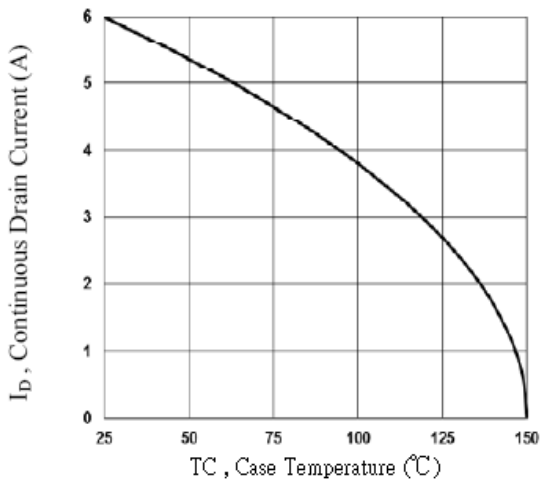
T<sub>J</sub>=25°C Unless otherwise noted

Symbol	Parameter	Conditions	Min	Typ	Max	Unit
<b>Static</b>						
V <sub>(BR)DSS</sub>	Drain-Source Breakdown Voltage	V <sub>GS</sub> =0V, I <sub>D</sub> =250uA	60			V
ΔBV <sub>DSS</sub> /ΔT <sub>J</sub>	BV <sub>DSS</sub> Temperature Coefficient	Reference to 25°C, I <sub>D</sub> =1mA		0.07		V/°C
V <sub>GS(th)</sub>	Gate Threshold Voltage		1.2	1.8	2.5	V
ΔV <sub>GS(th)</sub>	V <sub>GS(th)</sub> Temperature Coefficient	V <sub>DS</sub> =V <sub>GS</sub> , I <sub>D</sub> =250uA		5		mV/°C
I <sub>GSS</sub>	Gate Leakage Current	V <sub>DS</sub> =0V, V <sub>GS</sub> =±20V			±100	nA
I <sub>DSS</sub>	Zero Gate Voltage Drain Current	V <sub>DS</sub> =60V, V <sub>GS</sub> =0V			1	uA
		V <sub>DS</sub> =48V, V <sub>GS</sub> =0V, T <sub>J</sub> =125°C			10	
I <sub>S</sub>	Continuous Source Current	V <sub>G</sub> =V <sub>D</sub> =0V, Force Current			6	A
I <sub>SM</sub>	Pulsed Source Current				12	
R <sub>DS(on)</sub>	Drain-Source On-Resistance	V <sub>GS</sub> =10V, I <sub>D</sub> =3A		17	21	mΩ
		V <sub>GS</sub> =4.5V, I <sub>D</sub> =2A		20	24	
g <sub>FS</sub>	Forward Transconductance	V <sub>DS</sub> =10V, I <sub>D</sub> =10A		9		S
V <sub>SD</sub>	Diode Forward Voltage	V <sub>GS</sub> =0V, I <sub>S</sub> =1A			1	V
t <sub>rr</sub>	Reverse Recovery Time	V <sub>GS</sub> =0V, I <sub>S</sub> =1A, di/dt=100A/us		19.6		ns
Q <sub>rr</sub>	Reverse Recovery Charge			14.2		nC
<b>Dynamic</b>						
Q <sub>g</sub>	Total Gate Charge (*3,4)	V <sub>DS</sub> =30V, V <sub>GS</sub> =10V, I <sub>D</sub> =3A		28	42	nC
Q <sub>gs</sub>	Gate-Source Charge (*3,4)			3.5	7	
Q <sub>gd</sub>	Gate-Drain Charge (*3,4)			6.5	10	
C <sub>iss</sub>	Input Capacitance	V <sub>DS</sub> =20V, V <sub>GS</sub> =0V, f=1MHz		1680	2440	pF
C <sub>oss</sub>	Output Capacitance			115	170	
C <sub>rss</sub>	Reverse Transfer Capacitance			85	125	
t <sub>d(on)</sub>	Turn-On Time (*3,4)	V <sub>DD</sub> =30V, I <sub>D</sub> =1A, V <sub>GS</sub> =10V, R <sub>G</sub> =6Ω		7.2	14	ns
t <sub>r</sub>				38	72	
t <sub>d(off)</sub>	Turn-Off Time (*3,4)			34	65	
t <sub>f</sub>				8.2	16	
R <sub>g</sub>	Gate Resistance		V <sub>DS</sub> =0V, V <sub>GS</sub> =0V, f=1MHz		2.2	

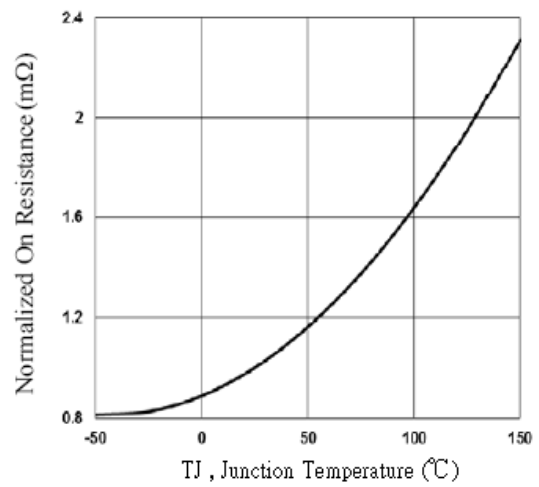
Note 3: The data tested by pulsed, pulse width ≤ 300us, duty cycle ≤ 2%.

Note 4: Essentially independent of operating temperature.

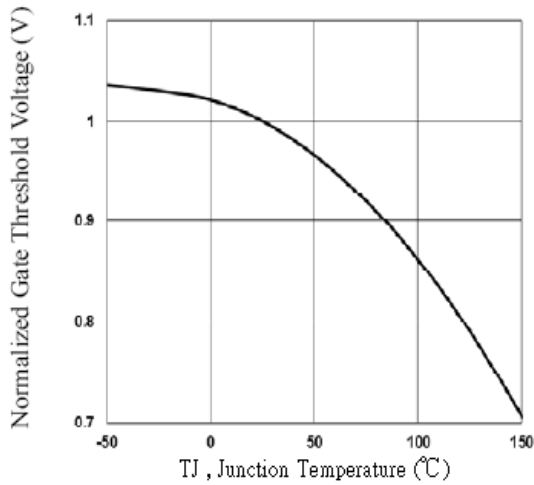
## Typical Performance Characteristics



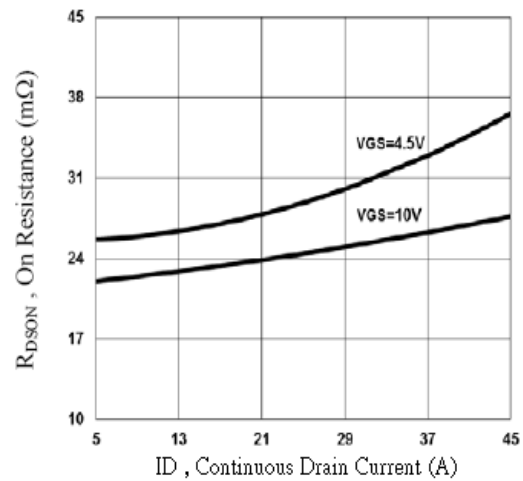
**Fig.1 Continuous Drain Current vs. T<sub>c</sub>**



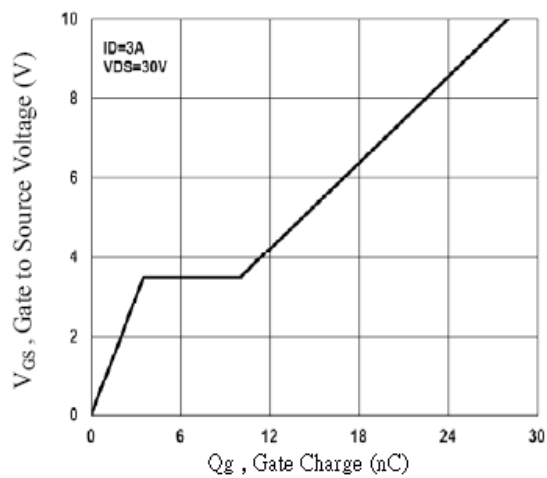
**Fig.2 Normalized RDS(on) vs. T<sub>j</sub>**



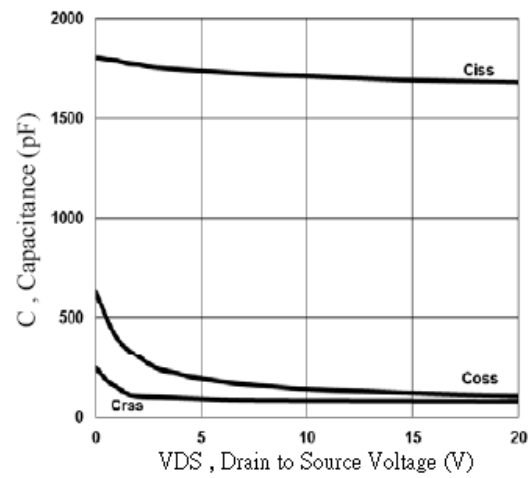
**Fig.3 Normalized V<sub>th</sub> vs. T<sub>j</sub>**



**Fig.4 RDS(on) vs. Continuous Drain Current**

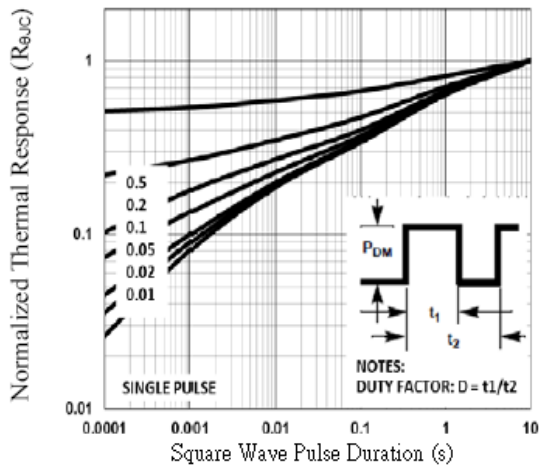


**Fig.5 Gate Charge Waveform**

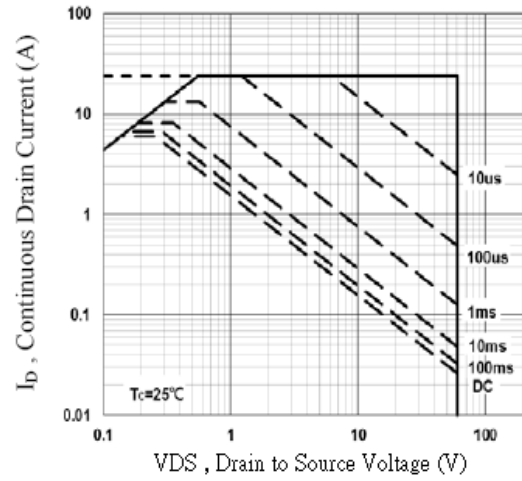


**Fig.6 Capacitance Characteristics**

## Typical Performance Characteristics (Continue)

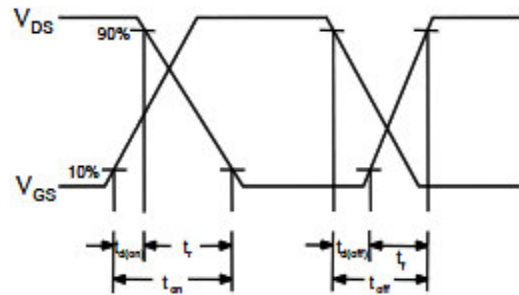
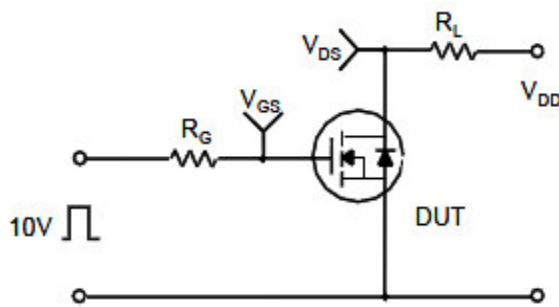


**Fig.7 Normalized Transient Impedance**

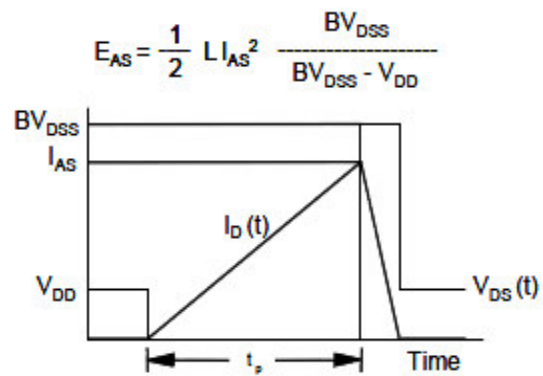
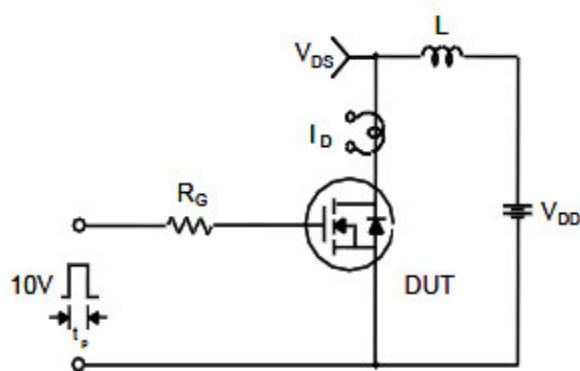


**Fig.8 Maximum Safe Operation Area**

### Resistive Switching Test Circuit & Waveforms

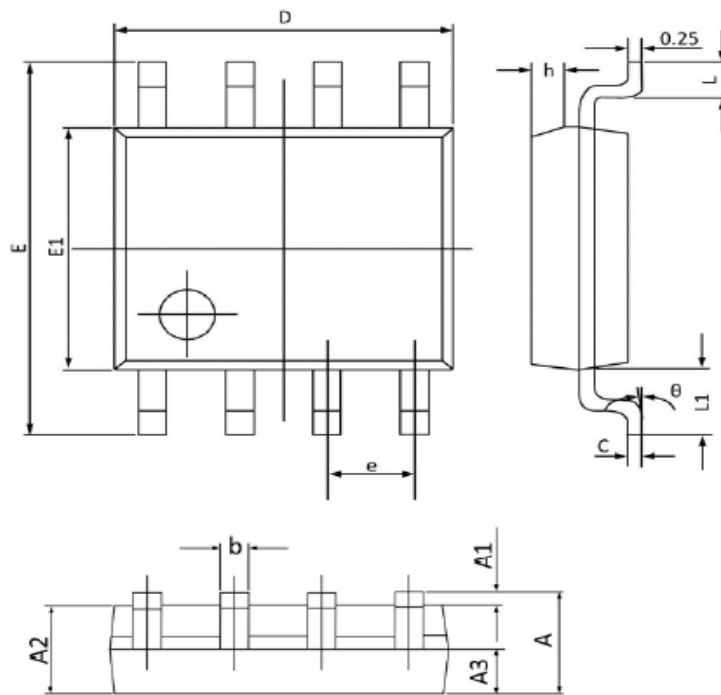


### Unclamped Inductive Switching Test Circuit & Waveforms



## Package Dimension

### SOP-8









Dimensions				
Symbol	Millimeters		Inches	
	Min	Max	Min	Max
A	1.350	1.750	0.053	0.068
A1	0.100	0.250	0.004	0.009
A2	1.300	1.500	0.052	0.059
A3	0.600	0.700	0.024	0.027
b	0.390	0.480	0.016	0.018
c	0.210	0.260	0.009	0.010
D	4.700	5.100	0.186	0.200
E	5.800	6.200	0.229	0.244
E1	3.700	4.100	0.146	0.161
e	1.270 (BSC)		0.050 (BSC)	
h	0.250	0.500	0.010	0.019
L	0.500	0.800	0.019	0.031
L1	1.050 (BSC)		0.041 (BSC)	
θ	0°	8°	0°	8°

## NOTICE

Information furnished is believed to be accurate and reliable. However Globaltech Semiconductor assumes no responsibility for the consequences of use of such information nor for any infringement of patents or other rights of third parties, which may result from its use. No license is granted by implication or otherwise under any patent or patent rights of Globaltech Semiconductor. Specifications mentioned in this publication are subject to change without notice. This publication supersedes and replaces all information without express written approval of Globaltech Semiconductor.

## CONTACT US

GS Headquarter	
	4F.,No.43-1,Lane11,Sec.6,Minquan E.Rd Neihu District Taipei City 114, Taiwan (R.O.C)
	886-2-2657-9980
	886-2-2657-3630
	sales_twn@gs-power.com

RD Division	
	824 Bolton Drive Milpitas. CA. 95035
	1-408-457-0587