

GSM7002KJZF

60V N-Channel Enhancement Mode MOSFET

Product Description

GSM7002KJZF, N-Channel enhancement mode MOSFET, uses Advanced Trench Technology to provide excellent $R_{DS(ON)}$, low gate charge.

These devices are particularly suited for low voltage power management, such as smart phone and notebook computer and other battery powered circuits, and low in-line power loss are needed in commercial industrial surface mount applications.

Features

- 60V/0.3A , $R_{DS(ON)}=3.0\Omega@V_{GS}=10V$
- 60V/0.2A , $R_{DS(ON)}=4.0\Omega@V_{GS}=4.5V$
- Super high density cell design for extremely low $R_{DS(ON)}$
- Exceptional on-resistance and maximum DC current capability
- ESD Protection (2KV) Diode design-in
- SOT-23 package design

Applications

- Drivers : Relays, Solenoids, Lamps, Hammers, Display, Memories, Transistors, etc.
- High saturation current capability.
Direct Logic-Level Interface: TTL/CMOS
- Battery Operated Systems
- Solid-State Relays

Packages & Pin Assignments

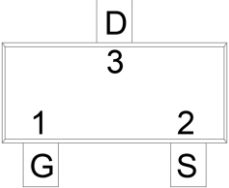
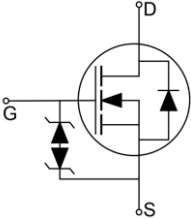
SOT-23			Equivalent Circuit		
					
Pin	Symbol	Description	Pin	Symbol	Description
1	G	Gate	3	D	Drain
2	S	Source			

Ordering and Marking Information

Ordering Information			
Part Number	Package	Part Marking	Quantity / Reel
GSM7002KJZF	SOT-23	e□□□□	3,000 PCS
GSM7002K 1 2 - Product Code: GSM7002K - Package Code: 1 is JZ for SOT-23 - Green Level: 2 is F for RoHS Compliant and Halogen Free			
Marking Information			
<div style="border: 1px solid black; padding: 5px; display: inline-block; margin-right: 20px;">e□□□□</div> - Product Code: e - GS Code: □□□□			

Absolute Maximum Ratings (T_A=25°C Unless otherwise noted)

Symbol	Parameter	Value	Unit
V _{DSS}	Drain-Source Voltage	60	V
V _{GSS}	Gate-Source Voltage - Continuous	±20	V
I _D	Continuous Drain Current	T _A =25°C	0.30
		T _A =70°C	0.21
I _{DM}	Pulsed Drain Current	0.65	A
I _S	Continuous Source Current (Diode Conduction)	0.45	A
P _D	Power Dissipation	T _A =25°C	0.35
		T _A =70°C	0.225
T _J	Operating Junction Temperature	-55 to 150	°C
T _{STG}	Storage Temperature Range	-55 to 150	°C
R _{θJA}	Thermal Resistance-Junction to Ambient	357	°C/W

Electrical Characteristics (T_A=25°C unless otherwise noted)

Symbol	Parameter	Conditions	Min	Typ	Max	Unit
Static characteristics						
V _{(BR)DSS}	Drain-Source Breakdown Voltage	V _{GS} =0V, I _D =250uA	60			V
V _{GS(th)}	Gate Threshold Voltage	V _{DS} =V _{GS} , I _D =250uA	1.0		2.0	
I _{GSS}	Gate Leakage Current	V _{DS} =0V, V _{GS} =±20V			3	uA
I _{DSS}	Zero Gate Voltage Drain Current	V _{DS} =60V, V _{GS} =0V			1	uA
		V _{DS} =60V, V _{GS} =0V, T _J =85°C			10	
R _{DS(on)}	Drain-Source On-Resistance	V _{GS} =10V, I _D =0.3A		1.9	3	Ω
		V _{GS} =4.5V, I _D =0.2A		2.4	4	
g _{FS}	Forward Transconductance	V _{DS} =10V, I _D =0.2A		0.2		S
V _{SD}	Diode Forward Voltage	V _{GS} =0V, I _S =0.2A		0.75	1.4	V
Dynamic characteristics						
Q _g	Total Gate Charge	V _{DD} =10V, I _D =0.25A, V _{GS} =4.5V		500		pC
Q _{gs}	Gate-Source Charge			100		
Q _{gd}	Gate-Drain Charge			150		
C _{iss}	Input Capacitance	V _{DS} = 25V, f =1MHz, V _{GS} =0V		30		pF
C _{oss}	Output Capacitance			8		
C _{rss}	Reverse Transfer Capacitance			5		
t _{d(on)}	Turn-On Time	V _{DD} =30V, I _D =0.2A, R _G =10Ω, V _{GEN} =4.5V, R _L =150Ω		10	20	ns
t _r				35	50	
t _{d(off)}	Turn-Off Time			20	30	
t _f				40	60	

Typical Performance Characteristics

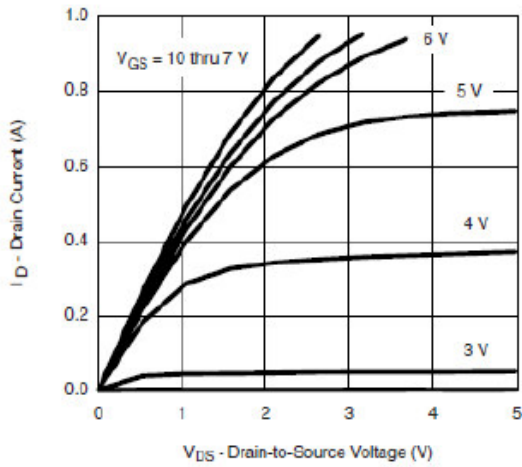

Output Characteristics

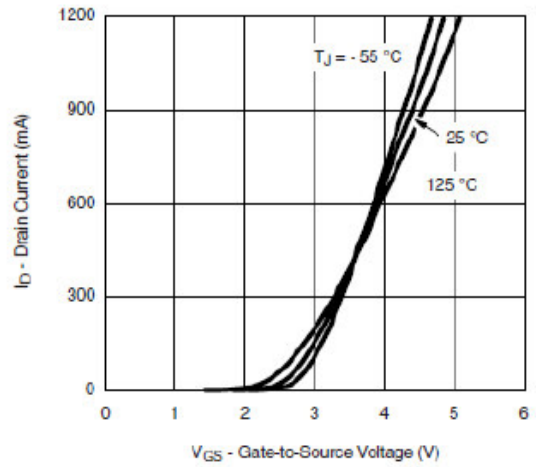

Transfer Characteristics

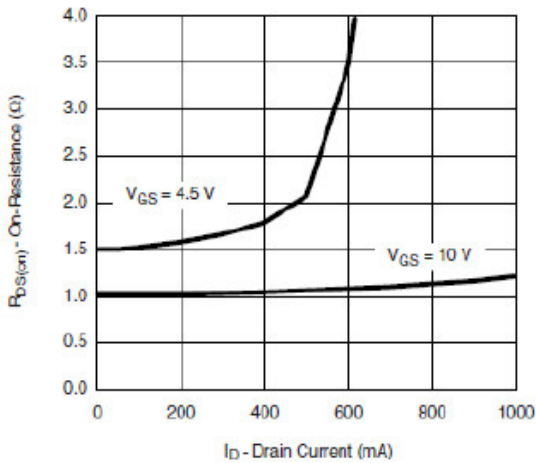

On-Resistance vs. Drain Current

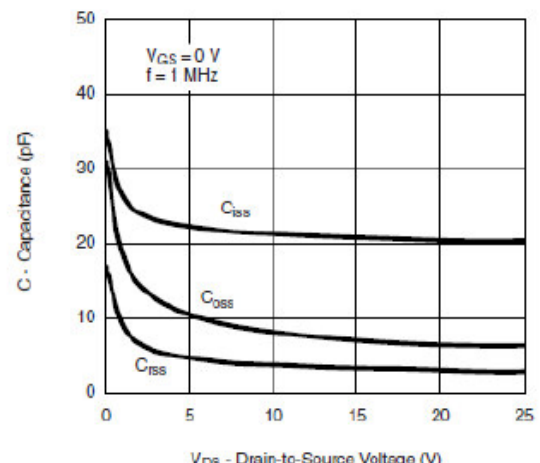

Capacitance

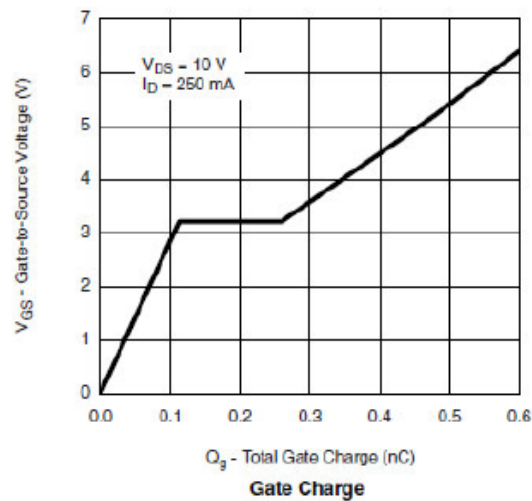

Gate Charge

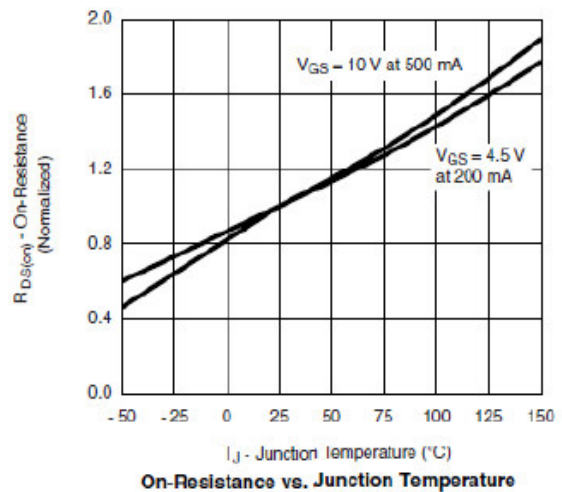

On-Resistance vs. Junction Temperature

Typical Performance Characteristics (Continue)

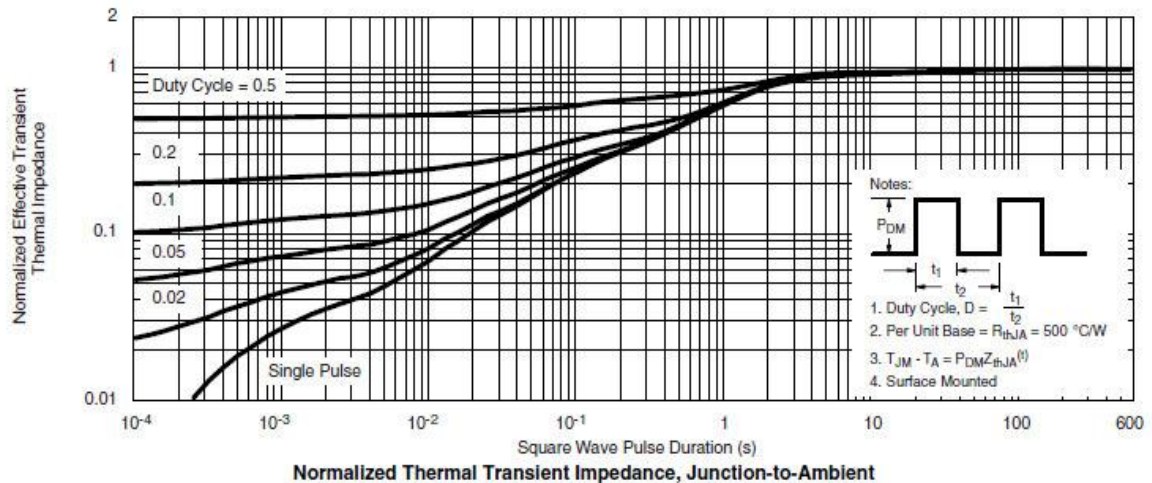
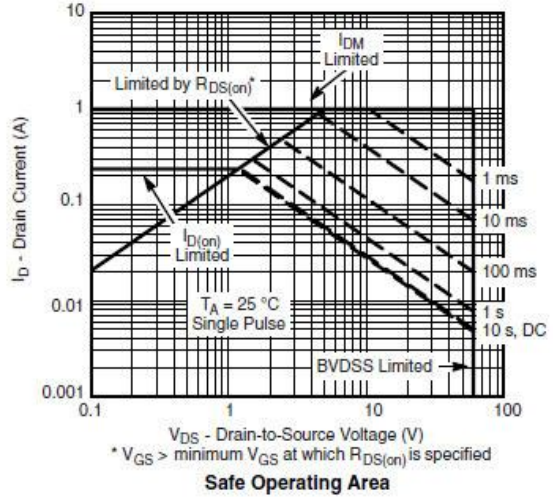
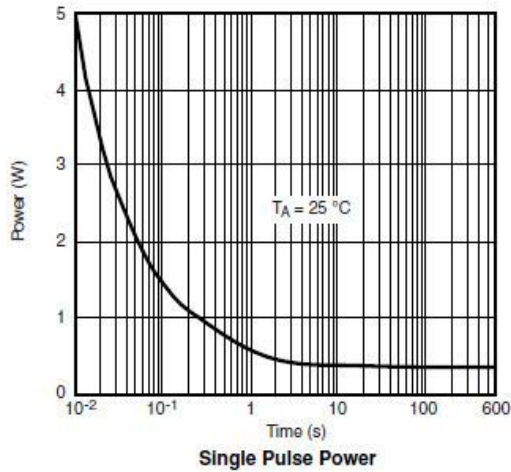
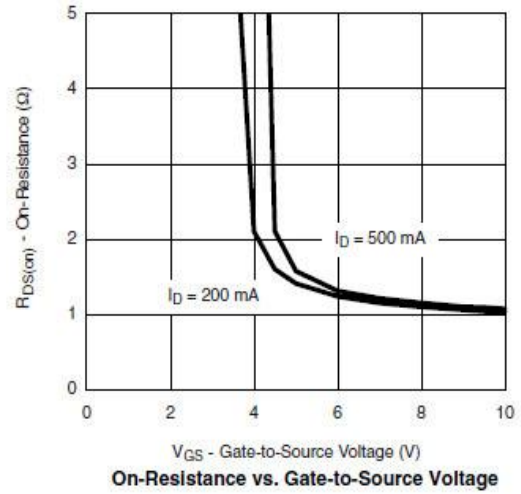
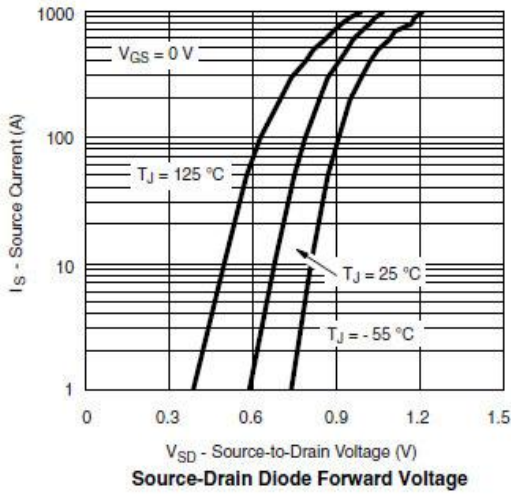

SOT-23

Package Dimension

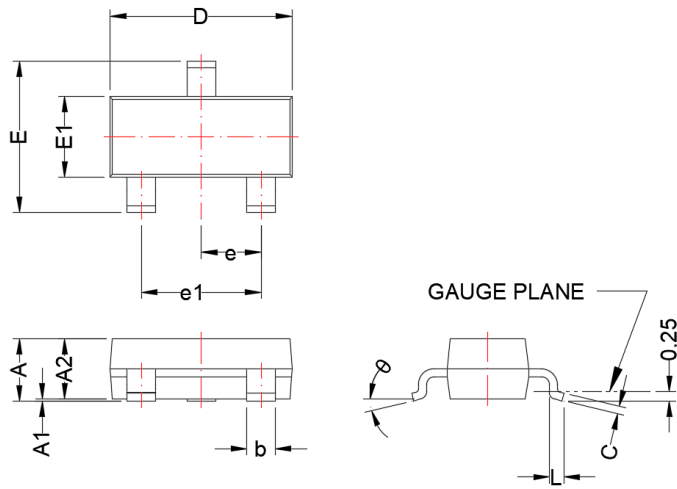

Recommended Land Pattern

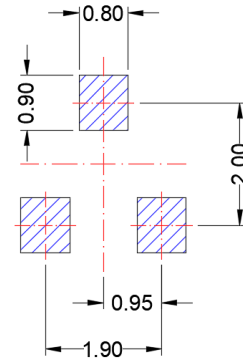

Unit:mm

Dimensions				
Symbol	Millimeters		Inches	
	MIN	MAX	MIN	MAX
A	0.75	1.17	0.030	0.046
A1	0.01	0.15	0.000	0.006
A2	0.70	1.02	0.028	0.040
b	0.30	0.50	0.012	0.020
c	0.08	0.20	0.003	0.008
D	2.80	3.04	0.110	0.120
E	2.10	2.64	0.083	0.104
E1	1.20	1.40	0.047	0.055
e	0.95 BSC		0.037 BSC	
e1	1.90 BSC		0.075 BSC	
L	0.30	0.60	0.012	0.024
θ	0°	8°	0°	8°





NOTE:



Dimensions are exclusive of Burrs, Mold Flash & Tie Bar extrusions.

NOTICE

- Globaltech Semiconductor assumes no responsibility for equipment failures that result from using products at values that exceed, even momentarily, rated values (such as maximum ratings, operating condition ranges, or other parameters) listed in products specifications of any and all Globaltech Semiconductor products described or contained herein. Globaltech Semiconductor products are not designed for use in life support appliances, devices or systems where malfunction of these products can be reasonably expected to result in personal injury. Reproduction in whole or in part is prohibited without the prior written consent of the copyright owner.
- Applications shown on the herein document are examples of standard use and operation. Customers are responsible in comprehending the suitable use in particular applications. Globaltech Semiconductor makes no representation or warranty that such applications will be suitable for the specified use without further testing or modification.
- Information furnished is believed to be accurate and reliable. However Globaltech Semiconductor assumes no responsibility for the consequences of use of such information nor for any infringement of patents or other rights of third parties, which may result from its use. No license is granted by implication or otherwise under any patent or patent rights of Globaltech Semiconductor. Specifications mentioned in this publication are subject to change without notice. This publication supersedes and replaces all information without express written approval of Globaltech Semiconductor.

CONTACT US

GS Headquarter	
	4F, NO.43-1, Lane 11, Sec. 6, Minquan E. Rd Neihu District, Taipei City 114761, Taiwan (R.O.C).
	886-2-2657-9980
	886-2-2657-3630
	sales_twn@gs-power.com

RD Division	
	824 Bolton Drive Milpitas. CA. 95035
	1-408-457-0587