

GSM4320DF

40V N-Channel MOSFET

Product Description

The N-Channel enhancement mode power field effect transistor is using trench DMOS technology. This advanced technology has been especially tailored to minimize on-state resistance, provide superior switching performance, and withstand high energy pulse in the avalanche and commutation mode.

The device is well suited for high efficiency fast switching applications.

Features

- $R_{DS(ON)} = 2.4m\Omega @ V_{GS}=10V$
- $R_{DS(ON)} = 3.6m\Omega @ V_{GS}=4.5V$
- TO-252-2L Package
- RoHS Compliant and Halogen Free

Applications

- MB / VGA / Vcore
- POL Applications
- SMPS

Packages & Pin Assignments

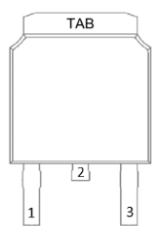
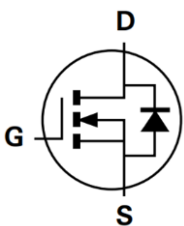
TO-252-2L			Equivalent Circuit		
					
Pin	Symbol	Description	Pin	Symbol	Description
1	G	Gate	2	D	Drain
3	S	Source	TAB	D	Drain

Ordering and Marking Information

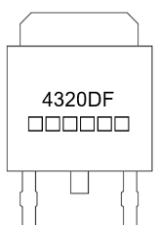
Ordering Information			
Part Number	Package	Part Marking	Quantity / Reel
GSM4320DF	TO-252-2L	4320DF □□□□□□	2,500 PCS
GSM4320 1 2			
- Product Code: GSM4320		- Package Code: 1 is D for TO-252-2L	
		- Green Level: 2 is F for RoHS Compliant and Halogen Free	
Marking Information			
		- Product Code: 4320DF	
		- GS Code: □□□□□□	

Absolute Maximum Ratings (T_A = 25°C unless otherwise specified)

Symbol	Parameter	Value	Unit	
V _{DSS}	Drain-Source Voltage	40	V	
V _{GSS}	Gate-Source Voltage	±20	V	
I _D	Continuous Drain Current (Silicon Limited)	T _C =25°C	127	A
		T _C =100°C	80	
	Continuous Drain Current (Package Limited)		80	
I _{DM}	Pulsed Drain Current ¹	320	A	
I _{AS}	Single Pulse Avalanche Current, L = 0.1mH ¹	40	A	
E _{AS}	Single Pulse Avalanche Energy, L = 0.1mH ¹	213	mJ	
P _D	Power Dissipation	T _C =25°C	78	W
		T _C =100°C	31	
R _{θJC}	Thermal Resistance-Junction to Case	1.6	°C/W	
R _{θJA}	Thermal Resistance-Junction to Ambient ²	62	°C/W	
T _J	Operating Junction Temperature Range	-55 to +150	°C	
T _{STG}	Storage Temperature Range	-55 to +150	°C	

NOTE:

- Single pulse width is limited by max junction temperature.
- The device mounted on 1in² FR-4 board with 2oz. Copper

Electrical Characteristics (T_J = 25°C unless otherwise specified)

Symbol	Parameter	Test Conditions	Min.	Typ.	Max.	Unit
Static Characteristics						
B _V DSS	Drain-Source Breakdown Voltage	V _{GS} =0V, I _D =250μA	40	-	-	V
I _{DSS}	Drain-Source Leakage Current	V _{DS} =40V, V _{GS} =0V	-	-	1	μA
I _{GSS}	Gate-Source Leakage Current	V _{DS} =0V, V _{GS} =±20V	-	-	±100	nA
V _{GS(th)}	Gate Threshold Voltage	V _{DS} =V _{GS} , I _D =250μA	1.2	-	2.5	V
R _{DS(ON)}	Drain-Source On-Resistance	V _{GS} =10V, I _D =20A	-	2	2.4	mΩ
		V _{GS} =4.5V, I _D =15A	-	2.8	3.6	
g _{fs}	Forward Transconductance	V _{DS} =5V, I _D =20A	-	42	-	S
Dynamic Characteristics						
R _g	Gate Resistance	f=1MHz		0.9		Ω
C _{iss}	Input Capacitance	V _{DS} =20V, V _{GS} =0V, f=1MHz	-	2950	-	pF
C _{oss}	Output Capacitance		-	980	-	
C _{rss}	Reverse Transfer Capacitance		-	78	-	
Q _g	Total Gate Charge	V _{DS} =20V, I _D =20A V _{GS} =10V	-	52	-	nC
Q _{gs}	Gate-Source Charge		-	8.3	-	
Q _{gd}	Gate-Drain Charge		-	14	-	
t _{d(on)}	Turn-On Delay Time	V _{DD} =20V, I _D =20A V _{GS} =10V, R _g =6Ω	-	10	-	ns
t _r	Turn-On Rise Time		-	15	-	
t _{d(off)}	Turn-Off Delay Time		-	20	-	
t _f	Turn-Off Fall Time		-	30	-	
Diode Characteristics						
V _{SD}	Diode Forward Voltage	V _{GS} =0V, I _S =1A	-	-	1	V
t _{rr}	Reverse Recovery Time	I _F =10A, dI/dt=100A/μs	-	70	-	ns
Q _{rr}	Reverse Recovery Charge		-	100	-	nC

Typical Performance Characteristics

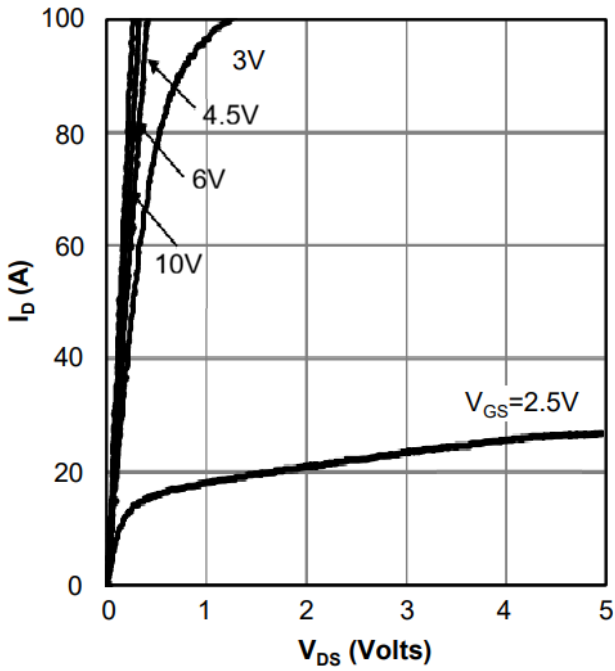

FIG.1 Output Characteristics

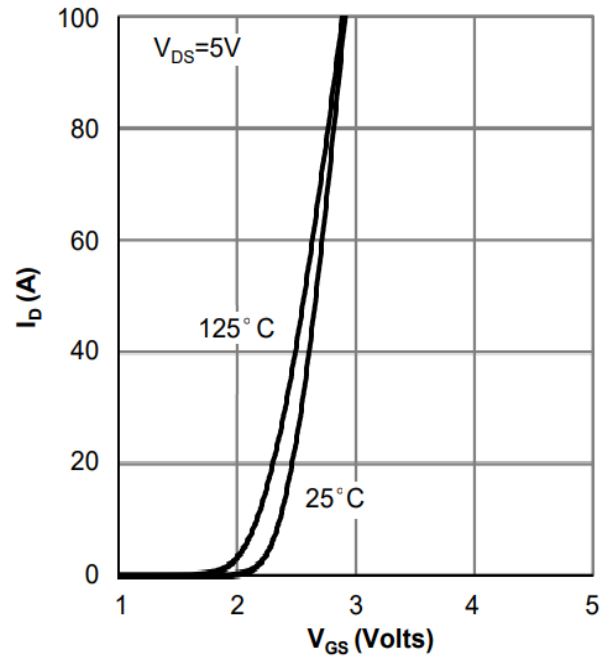

FIG.2 Transfer Characteristics

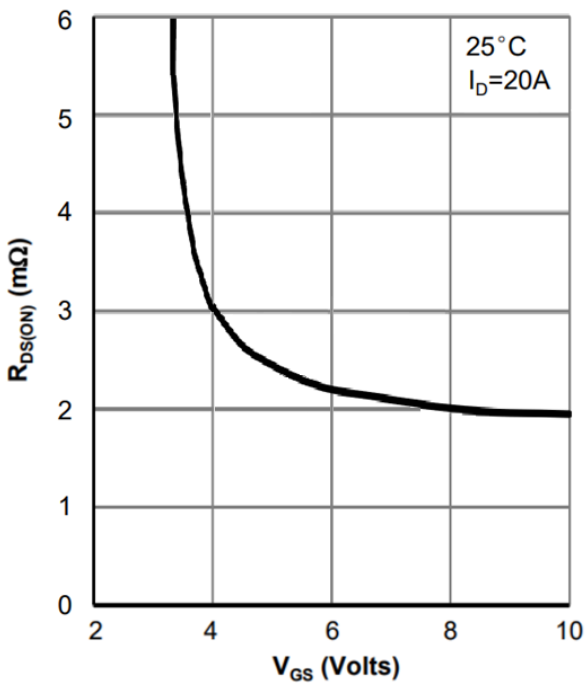

FIG.3 On-Resistance vs. Gate Voltage

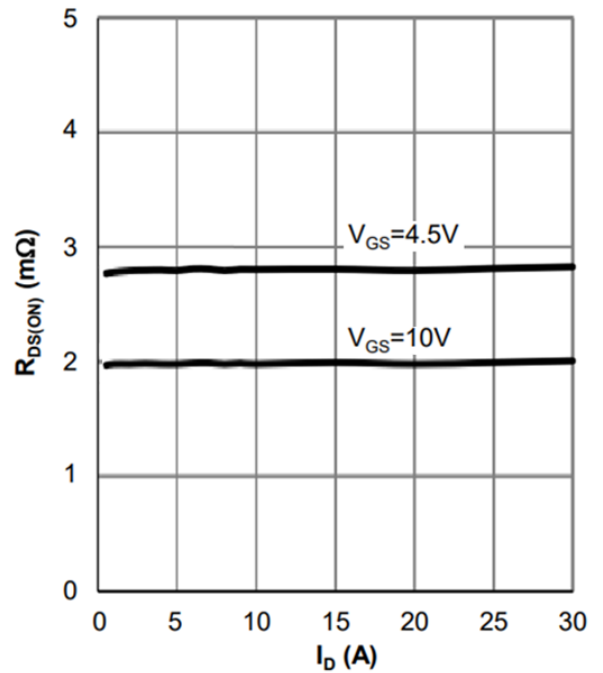

FIG.4 On-Resistance vs. Drain Current

Typical Performance Characteristics

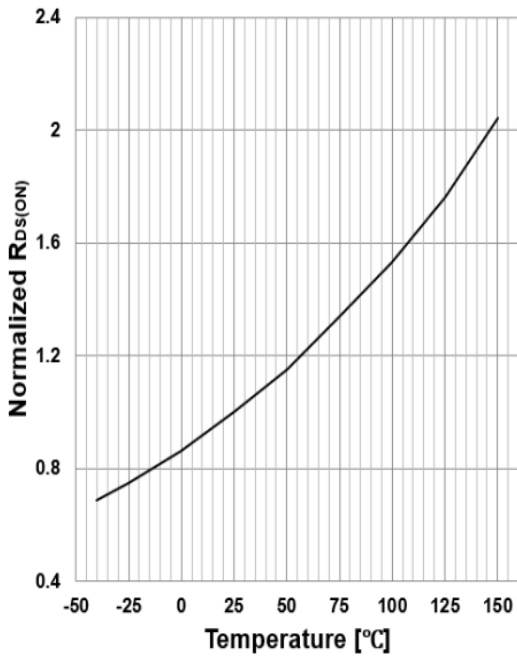

FIG.5 Normalized On-Resistance vs. T_J

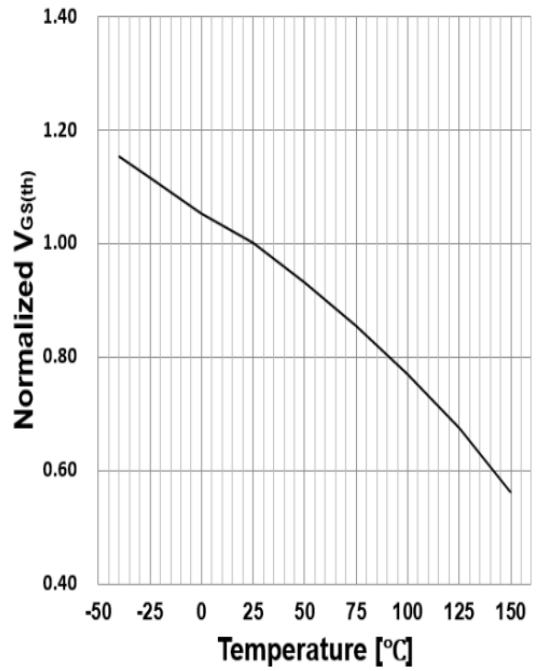

FIG.6 Normalized $V_{GS(th)}$ vs. T_J

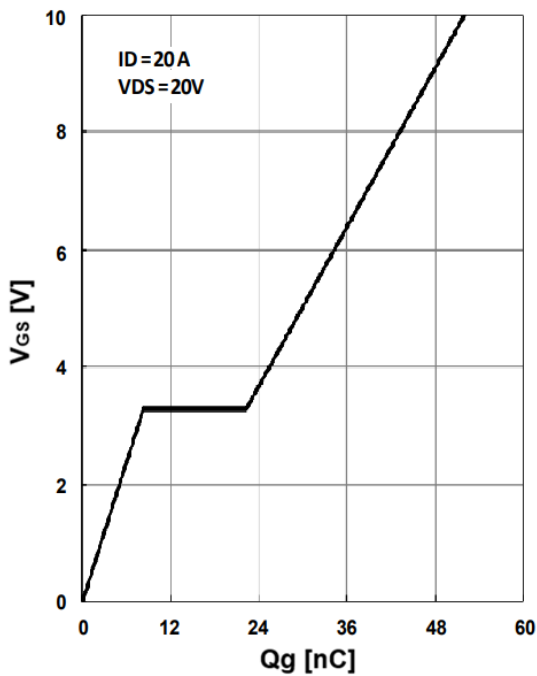

FIG.7 Gate Charge Characteristics

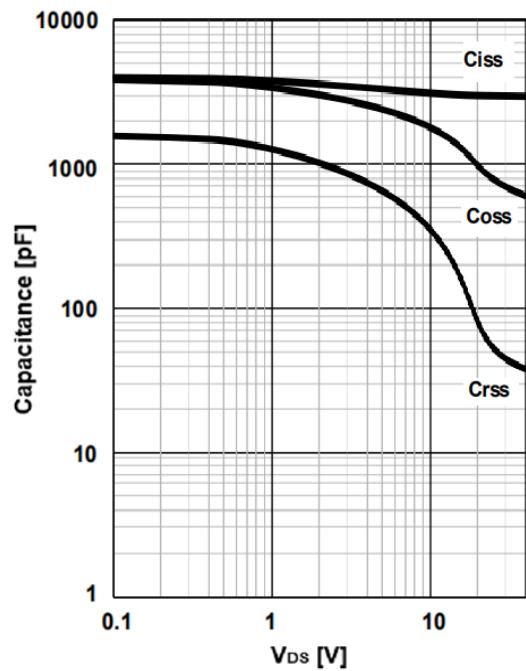

FIG.8 Capacitance Characteristics

Typical Performance Characteristics

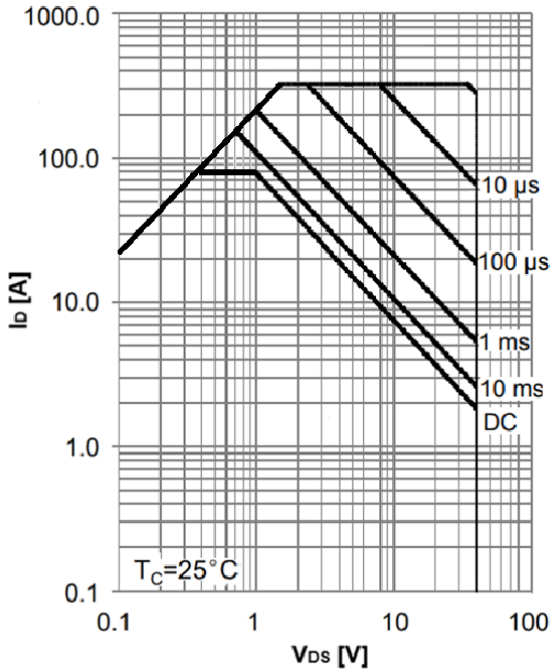

FIG.9 Maximum Safe Operation Area

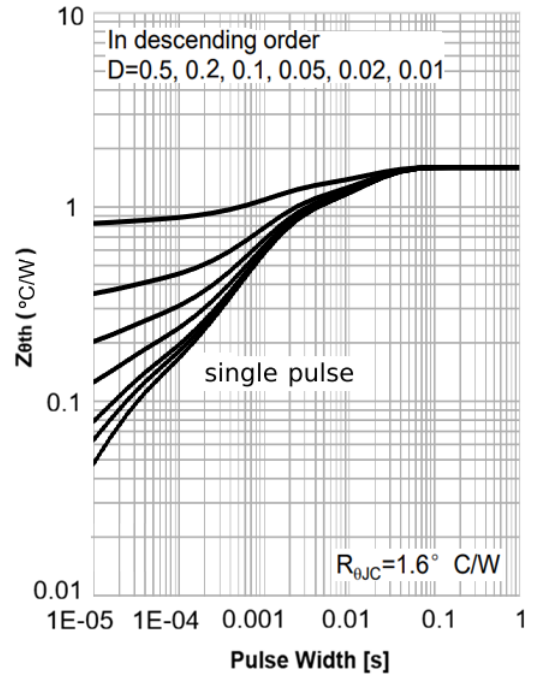

FIG.10 Transient Thermal Impedance

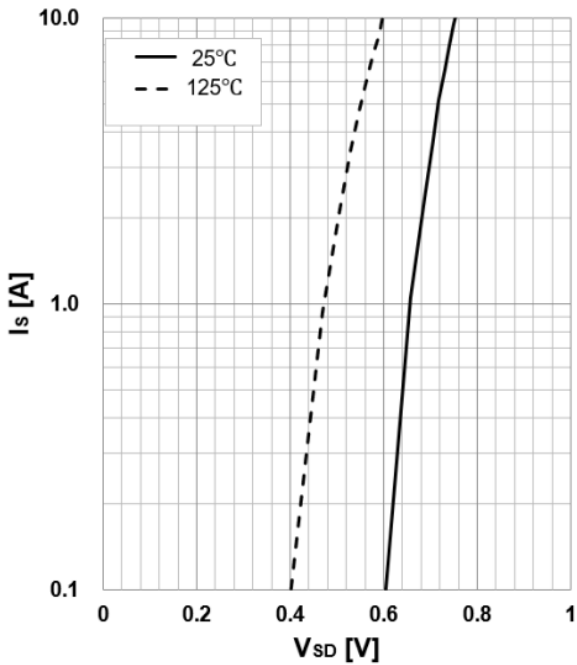
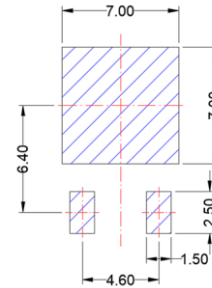
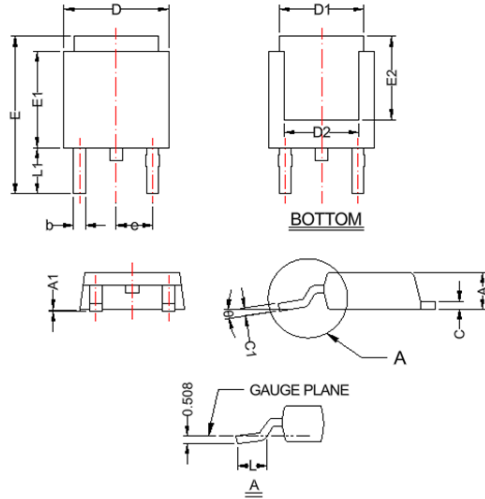

FIG.11 Body-Diode Characteristics

TO-252-2L(AA)

Package Dimension (2)

Recommended Land Pattern



Unit:mm

Dimensions (1)				
Symbol	Millimeters		Inches	
	Min	Max	Min	Max
A	2.18	2.40	0.086	0.094
A1	0.00	0.15	0.000	0.006
b	0.64	0.90	0.025	0.035
c	0.40	0.89	0.016	0.035
c1	0.40	0.61	0.016	0.024
D	6.35	6.73	0.250	0.265
D1	4.95	5.46	0.195	0.215
D2	4.32	---	0.170	---
E	9.40	10.41	0.370	0.410
E1	5.97	6.22	0.235	0.245
E2	4.95	---	0.195	---
e	2.286 BSC		0.090 BSC	
L	1.40	1.77	0.055	0.070
L1	2.67	3.07	0.105	0.121
θ	0°	8°	0°	8°

NOTE:

- Dimensions are exclusive of Burrs, Mold Flash and Tie Bar extrusions.
- The drawing is used to express the dimension while the actual appearance may vary

TO-252-2L(AB)

Package Dimension (2)

Recommended Land Pattern

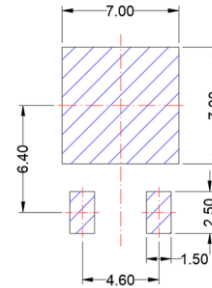
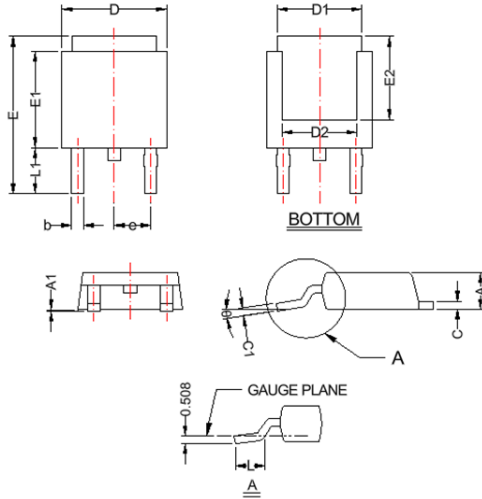

Unit:mm

Dimensions (1)				
Symbol	Millimeters		Inches	
	Min	Max	Min	Max
A	2.18	2.40	0.086	0.094
A1	0.00	0.15	0.000	0.006
b	0.50	0.90	0.020	0.035
c	0.45	0.89	0.018	0.035
c1	0.40	0.61	0.016	0.024
D	6.35	6.80	0.250	0.268
D1	4.95	5.50	0.195	0.217
D2	3.81	---	0.150	---
E	9.40	10.41	0.370	0.410
E1	5.33	5.80	0.210	0.228
E2	4.57	---	0.180	---
e	2.286 BSC		0.090 BSC	
L	1.40	1.78	0.055	0.070
L1	2.40	3.00	0.094	0.118
θ	0°	8°	0°	8°





NOTE:



- 1 Dimensions are exclusive of Burrs, Mold Flash and Tie Bar extrusions.
- 2 The drawing is used to express the dimension while the actual appearance may vary

NOTICE

- Globaltech Semiconductor assumes no responsibility for equipment failures that result from using products at values that exceed, even momentarily, rated values (such as maximum ratings, operating condition ranges, or other parameters) listed in products specifications of any and all Globaltech Semiconductor products described or contained herein. Globaltech Semiconductor products are not designed for use in life support appliances, devices or systems where malfunction of these products can be reasonably expected to result in personal injury. Reproduction in whole or in part is prohibited without the prior written consent of the copyright owner.
- Applications shown on the herein document are examples of standard use and operation. Customers are responsible in comprehending the suitable use in particular applications. Globaltech Semiconductor makes no representation or warranty that such applications will be suitable for the specified use without further testing or modification.
- Information furnished is believed to be accurate and reliable. However Globaltech Semiconductor assumes no responsibility for the consequences of use of such information nor for any infringement of patents or other rights of third parties, which may result from its use. No license is granted by implication or otherwise under any patent or patent rights of Globaltech Semiconductor. Specifications mentioned in this publication are subject to change without notice. This publication supersedes and replaces all information without express written approval of Globaltech Semiconductor.

CONTACT US

GS Headquarter	
	4F, NO.43-1, Lane 11, Sec. 6, Minquan E. Rd Neihu District, Taipei City 114761, Taiwan (R.O.C).
	886-2-2657-9980
	886-2-2657-3630
	sales_twn@gs-power.com

RD Division	
	824 Bolton Drive Milpitas. CA. 95035
	1-408-457-0587