

GSM3118RF

30V N-Channel MOSFETs

Product Description

These N-Channel enhancement mode power field effect transistors are using trench DMOS technology. This advanced technology has been especially tailored to minimize on-state resistance, provide superior switching performance, and withstand high energy pulse in the avalanche and commutation mode.

These devices are well suited for high efficiency fast switching applications.

Features

- 30V, 6.5A, $R_{DS(ON)}=24m\Omega@V_{GS}=10V$
- Improved dv/dt capability
- Fast switching
- Green Device Available
- SOT-23-6L package design

Applications

- MB / VGA / Vcore
- Load Switch
- Hand-Held Instrument

Packages & Pin Assignments

GSM3118RF (SOT-23-6L)

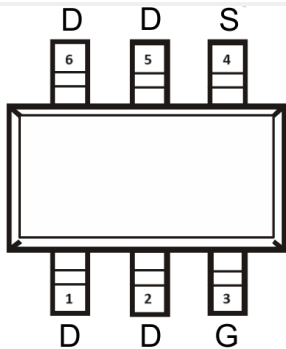

Top Views

Pin	Description
1	Drain
2	Drain
3	Gate
4	Source
5	Drain
6	Drain

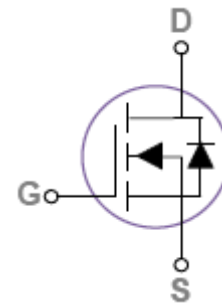

Ordering Information

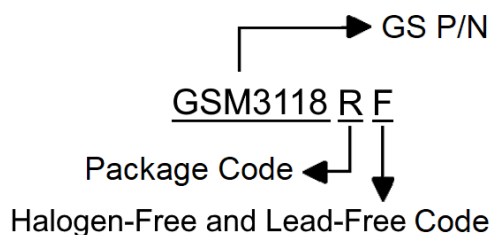

Marking Information

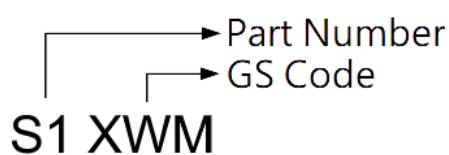

Part Number	Package	Part Marking	Quantity
GSM3118RF	SOT-23-6L	S1XWM	3000pcs

Absolute Maximum Ratings

$T_A=25^{\circ}\text{C}$ Unless otherwise noted

Symbol	Parameter	Typical	Unit
V_{DS}	Drain-Source Voltage	30	V
V_{GS}	Gate-Source Voltage	± 20	V
I_D	Continuous Drain Current	$T_A=25^{\circ}\text{C}$	6.5
		$T_A=70^{\circ}\text{C}$	5.2
I_{DM}	Pulsed Drain Current	26	A
EAS	Single Pulse Avalanched Energy	3.2	mJ
IAS	Single Pulse Avalanched Current	8	A
P_D	Power Dissipation	$T_A=25^{\circ}\text{C}$	1.56
		$T_A=70^{\circ}\text{C}$	1
T_J	Operating Junction Temperature Range	-55 to +150	$^{\circ}\text{C}$
T_{STG}	Storage Temperature Range	-55 to +150	$^{\circ}\text{C}$
$R_{\theta JA}$	Thermal Resistance-Junction to Ambient	80	$^{\circ}\text{C}/\text{W}$

Electrical Characteristics

T_A=25°C Unless otherwise noted

Symbol	Parameter	Conditions	Min	Typ	Max	Unit
Static						
V _{(BR)DSS}	Drain-Source Breakdown Voltage	V _{GS} =0V, I _D =250uA	30			V
V _{GS(th)}	Gate Threshold Voltage	V _{DS} =V _{GS} , I _D =250uA	1.2	1.6	2.5	V
I _{GSS}	Gate Leakage Current	V _{DS} =0V, V _{GS} =±20V			±100	nA
I _{DSS}	Zero Gate Voltage Drain Current	V _{DS} =30V, V _{GS} =0V			1	uA
		V _{DS} =24V, V _{GS} =0V, T _J =125°C			10	
R _{DS(on)}	Drain-Source On-Resistance	V _{GS} =10V, I _D =6A		19	24	mΩ
		V _{GS} =4.5V, I _D =4A		25	30	
g _{FS}	Forward Transconductance	V _{DS} =10V, I _D =4A		6.5		S
V _{SD}	Diode Forward Voltage	V _{GS} =0V, I _S =1A			1	V
Dynamic						
Q _g	Total Gate Charge	V _{DS} =15V, V _{GS} =4.5V, I _D =5A		4.1	8	nC
Q _{gs}	Gate-Source Charge			1	2	
Q _{gd}	Gate-Drain Charge			2.1	4	
C _{iss}	Input Capacitance	V _{DS} =25V, V _{GS} =0V, f=1MHz		345	500	pF
C _{oss}	Output Capacitance			55	80	
C _{rss}	Reverse Transfer Capacitance			32	45	
t _{d(on)}	Turn-On Time	V _{DD} =15V, I _D =1A, V _{GS} =10V, R _G =6Ω		2.8	5	ns
t _r				7.2	14	
t _{d(off)}	Turn-Off Time			15.8	30	
t _f				4.6	9	
R _g	Gate Resistance	V _{DS} =0V, V _{GS} =0V, f=1MHz		3.2	6.4	Ω

Typical Performance Characteristics

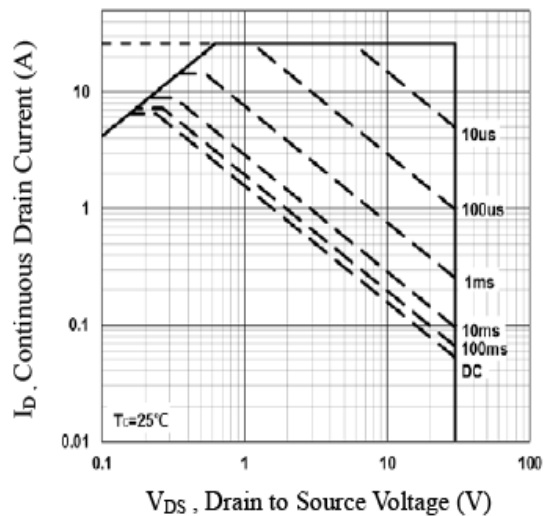
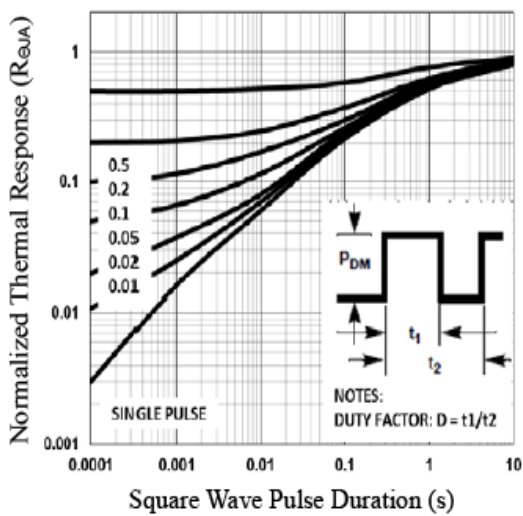
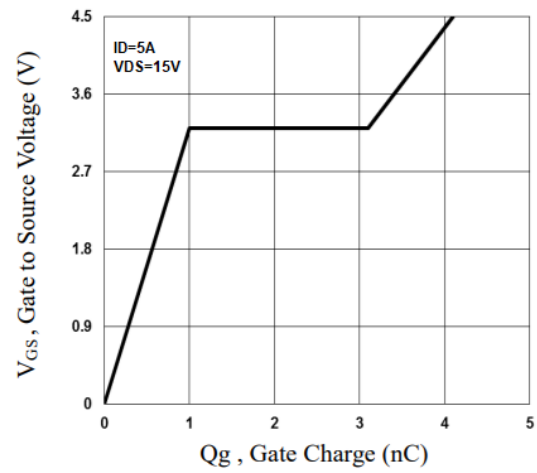
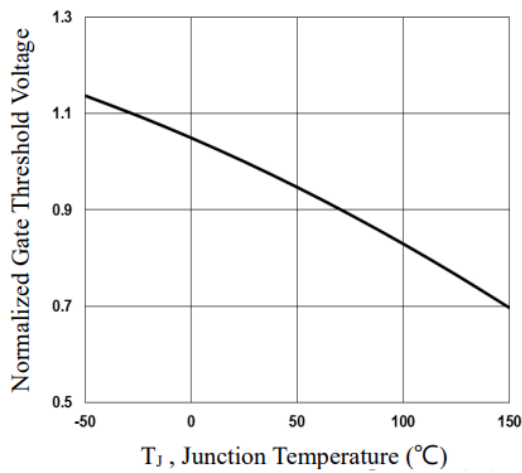
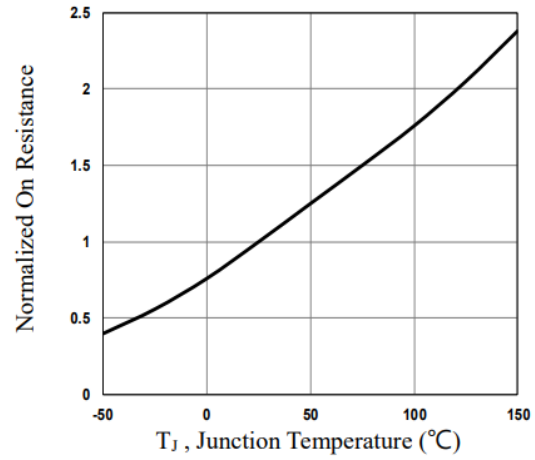
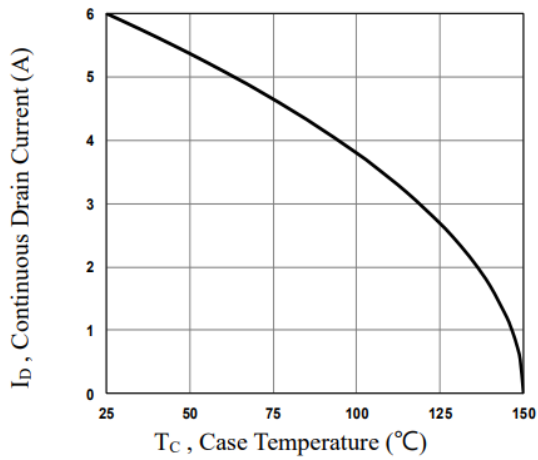

Typical Performance Characteristics (Continue)

Gate Charge Test Circuit & Waveform

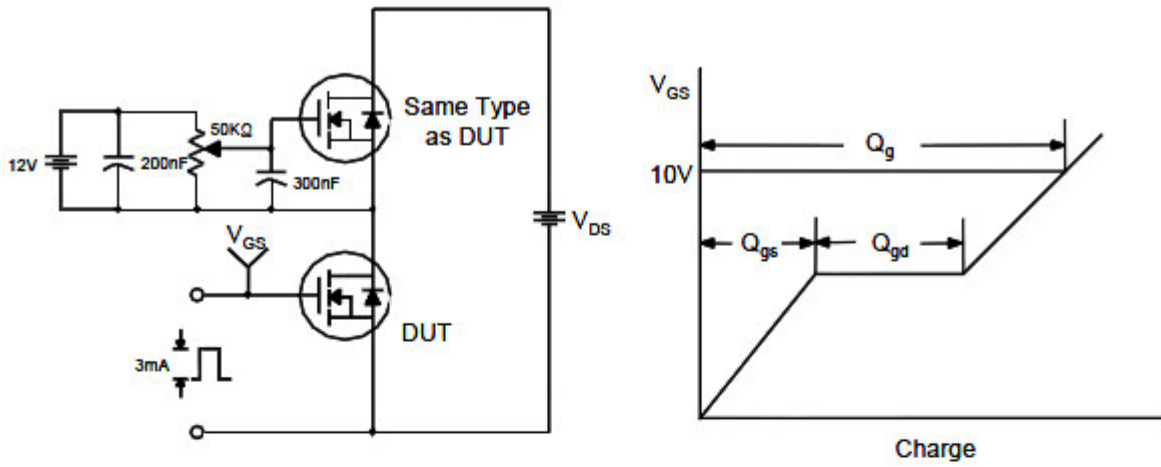

Resistive Switching Test Circuit & Waveforms

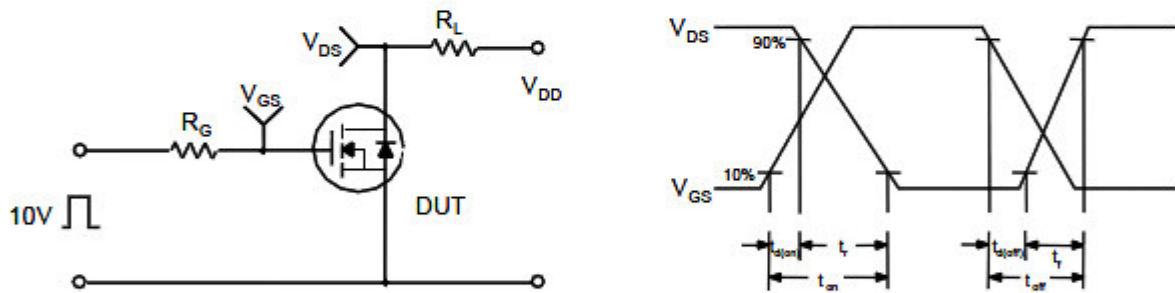

Unclamped Inductive Switching Test Circuit & Waveforms

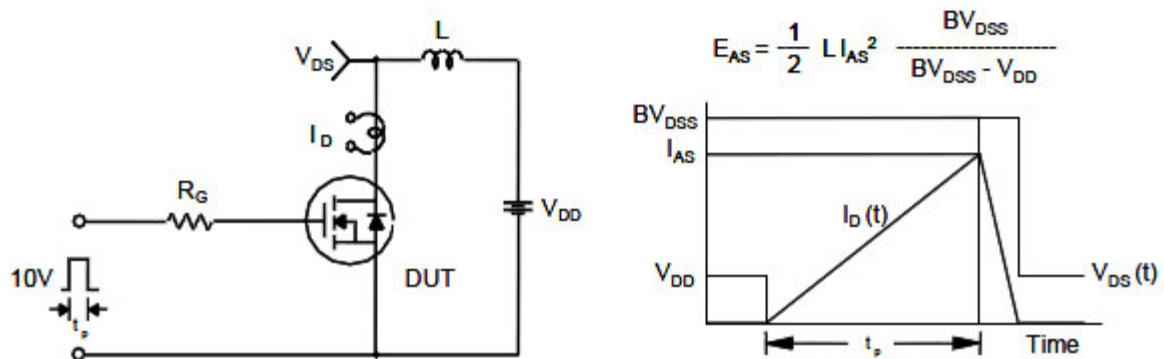

Package Dimension

SOT-23-6L

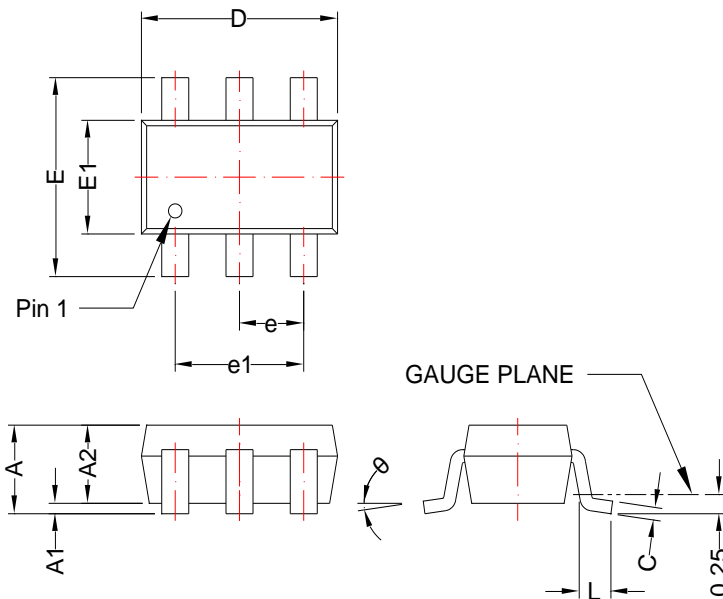

DIMENSION D DOES NOT INCLUDE MOLD FLASH, PROTRUSIONS OR GATE BURRS. MOLD FLASH, PROTRUSIONS OR GATE BURRS SHALL NOT EXCEED 0.25mm PER INTERLEAD FLASH OR PROTRUSION SHALL NOT EXCEED 0.25mm PER SIDE.

Dimensions				
Symbol	Millimeters		Inches	
	Min	Max	Min	Max
A	0.90	1.45	0.035	0.057
A1	0.00	0.15	0.000	0.006
A2	0.90	1.30	0.035	0.051
b	0.30	0.50	0.012	0.020
c	0.08	0.26	0.003	0.010
D	2.70	3.10	0.106	0.122
E	2.20	3.00	0.087	0.118
E1	1.30	1.75	0.051	0.069
A	0.90	1.45	0.035	0.057
A1	0.00	0.15	0.000	0.006
e	0.95 BSC		0.037 BSC	
e1	1.90 BSC		0.075 BSC	
L	0.3	0.6	0.012	0.024
θ	0°	8°	0°	8°





NOTICE



- Globaltech Semiconductor assumes no responsibility for equipment failures that result from using products at values that exceed, even momentarily, rated values (such as maximum ratings, operating condition ranges, or other parameters) listed in products specifications of any and all Globaltech Semiconductor products described or contained herein. Globaltech Semiconductor products are not designed for use in life support appliances, devices or systems where malfunction of these products can be reasonably expected to result in personal injury. Reproduction in whole or in part is prohibited without the prior written consent of the copyright owner.

- Applications shown on the herein document are examples of standard use and operation. Customers are responsible in comprehending the suitable use in particular applications. Globaltech Semiconductor makes no representation or warranty that such applications will be suitable for the specified use without further testing or modification.

- Information furnished is believed to be accurate and reliable. However Globaltech Semiconductor assumes no responsibility for the consequences of use of such information nor for any infringement of patents or other rights of third parties, which may result from its use. No license is granted by implication or otherwise under any patent or patent rights of Globaltech Semiconductor. Specifications mentioned in this publication are subject to change without notice. This publication supersedes and replaces all information without express written approval of Globaltech Semiconductor.

CONTACT US

GS Headquarter	
	4F.,No.43-1,Lane11,Sec.6,Minquan E.Rd Neihsu District Taipei City 114, Taiwan (R.O.C)
	886-2-2657-9980
	886-2-2657-3630
	sales_twn@gs-power.com

RD Division	
	824 Bolton Drive Milpitas. CA. 95035
	1-408-457-0587