

# GS2231A

## 3A Ultra-Low Dropout Voltage Regulator

### Product Description

The GS2231A is a 3A low dropout linear regulator designed for low dropout and high current applications. This device works with dual supplies, a control input for the control circuitry and a power input as low as 1.05V for providing current to output. It features 3A output current and ultra-low-drop output voltage as well as full protection functions.  $V_{OUT}$  can be as low as 0.8V. The other features include soft start, under voltage protection, current limit protection, Power-On-Reset function, and over temperature protection. The GS2231A is available in DFN3x3-10L and PSOP8 packages.

### Features

- $V_{IN}$  Range 1.05V to 5.5V
- Adjustable Output Voltages to 0.8V Min
- 250mV Typical Dropout at 3A
- Current Limit Protection
- Thermal Shutdown Protection
- $V_{OUT}$  Power OK Signal
- $V_{OUT}$  Pull Low Resistance when Disabled
- RoHS Compliant

### Applications

- Notebook, Netbook, Graphic Cards
- Low Voltage Logic Supplies
- Chipset Supplies
- SMPS Post Regulators

### Function Block Diagram

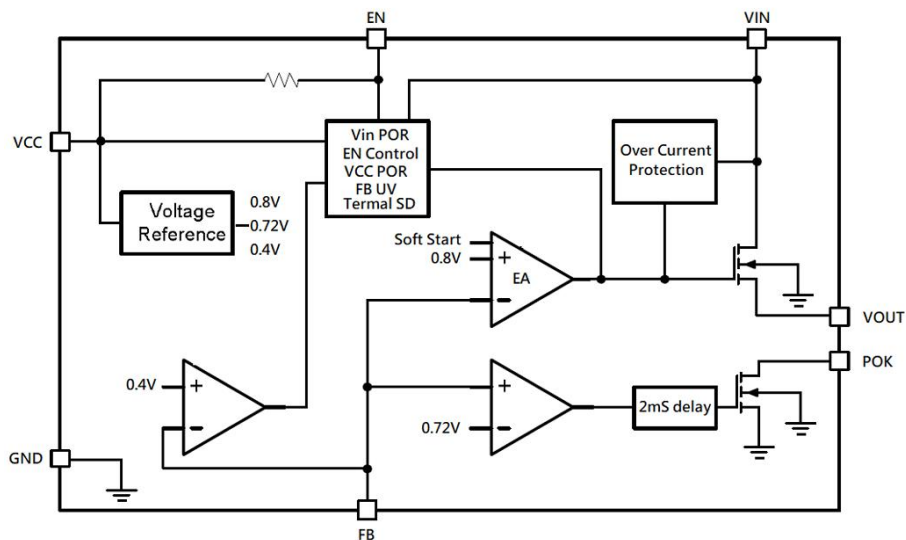

## Pin Configuration & Description

TOP VIEW			
<b>PSOP-8</b>		<b>DFN3x3-10L</b>	
Pin Name	Pin No. (PSOP-8)	Pin No. (DFN3x3-10L)	Pin Function
<b>P<sub>OK</sub></b>	<b>1</b>	<b>5</b>	Power OK indication, open drain output.
<b>EN</b>	<b>2</b>	<b>6</b>	Enable pin. Internal pull high to V <sub>CC</sub>
<b>V<sub>IN</sub></b>	<b>3</b>	<b>7, 8 &amp; 9</b>	Supply input of power.
<b>V<sub>CC</sub></b>	<b>4</b>	<b>10</b>	Supply input of control circuit.
<b>N.C.</b>	<b>5</b>	<b>-</b>	Non connection
<b>V<sub>OUT</sub></b>	<b>6</b>	<b>1, 2 &amp; 3</b>	Output Voltage
<b>FB</b>	<b>7</b>	<b>4</b>	Feedback Pin
<b>GND</b>	<b>8 &amp; 9 (Exposed Pad)</b>	<b>11 (Exposed Pad)</b>	Ground Pin (The exposed pad must be soldered to a PCB and be connected to GND for maximum power dissipation.)

## Ordering and Marking Information

Part Number	Package	Marking Information			
		Product Code	Package Code	Lead Free	GS Code
GS2231APSF	PSOP-8	GS2231A	PS	F	XXXX
GS2231AZFF	DFN3x3-10L	GS2231A	ZF	F	XXXX

## Absolute Maximum Ratings

Supply Voltage, $V_{IN}$	-0.3V ~ 6V	
Supply Voltage for Control Circuit, $V_{CC}$	-0.3V ~ 6V	
Other Pins	-0.3V ~ ( $V_{CC} + 0.3V$ )	
Maximum Junction Temperature, $T_J$	150°C	
Power Dissipation, $P_D$	2.2W	
Junction-to-Ambient Thermal Resistance, $\theta_{JA}$	55°C/W	
Junction-to-Case Thermal Resistance, $\theta_{JC}$	20 °C/W	
Lead Temperature (Soldering, 10 sec)	300°C	
Storage Temperature Range	-65°C to 150°C	
ESD Rating	HBM	2KV
	MM	200V

Note1: Stresses greater than those listed under Maximum Ratings may cause permanent damage to the device. This is a stress rating only and functional operation of the device at these or any other conditions above those indicated in the operation is not implied. Exposure to absolute maximum rating conditions for extended periods may affect reliability.

## Recommended Operating Conditions

Symbol	Parameter	Range	Unit
$V_{IN}$	Supply Voltage	1.05 ~ $V_{CC}$	V
$V_{CC}$	Supply Voltage for Control Circuit ( $V_{CC} > V_{OUT} + 1.5V$ )	3.0 ~ 5.5	V
$I_{OUT}$	Output Current	0 ~ 3	A
R2	Refer to Typical Application Circuit	10K	$\Omega$
$T_A$	Ambient Temperature Range	-40 ~ 85	°C

## Electrical Characteristics

$V_{CC}= 5V$  and  $T_A= 25^\circ C$ , unless otherwise specified.

Symbol	Parameters	Condition	Min	Typ	Max	Units
$V_{CC}$	$V_{CC}$ Operating Range		3.0		5.5	V
$V_{CC\_POR}$	$V_{CC}$ POR Threshold	$V_{CC}$ Rising	2.2	2.8	3.0	V
$\Delta V_{CC\_POR}$	$V_{CC}$ POR Hysteresis	$V_{CC}$ Falling	-	0.4	-	V
$V_{IN}$	$V_{IN}$ Operating Range		1.05		$V_{CC}$	V
$V_{IN\_POR}$	$V_{IN}$ POR Threshold	$V_{IN}$ Rising	0.8	-	1.0	V
$\Delta V_{IN\_POR}$	$V_{IN}$ POR Hysteresis	$V_{IN}$ Falling	-	0.35	-	V
$I_Q$	Quiescent Current	$V_{IN}=V_{CC}=V_{EN}=5.0V$ $I_{OUT}=0A$	-	0.9	1.5	mA
$I_{CC\_SD}$	Control Input Current in Shutdown	$V_{IN}=V_{CC}=5.0V$ $V_{EN}=0V$	-	10	30	$\mu A$
$V_{REF}$	Reference Voltage of FB		0.785	0.8	0.815	V
$\Delta V_{LOAD}$	Load Regulation	$V_{IN}=V_{CC}=V_{EN}=5.0V$ $I_{OUT}=0$ to 3A	-	0.1	0.5	%/A
$\Delta V_{LINE}$	Line Regulation	$V_{CC}=V_{EN}=5.0V$ $I_{OUT}=1mA$ $V_{IN}=1.05$ to 5.0V	-	0.01	0.1	%/V

## Electrical Characteristics (Continued)

Symbol	Parameters	Condition	Min	Typ	Max	Units
V <sub>DROP</sub>	Dropout Voltage	V <sub>OUT</sub> =1.6V I <sub>OUT</sub> =3A	-	250	360	mV
I <sub>LIM</sub>	Current Limit	-	-	5.5	-	A
R <sub>PULL</sub>	V <sub>OUT</sub> Pull-Low Resistance	V <sub>EN</sub> =0V	-	-	150	Ω
t <sub>SS</sub>	Output Voltage Ramp Up Time		0.6	1	2	ms
<b>Enable</b>						
I <sub>EN</sub>	EN Input Bias Current	V <sub>EN</sub> =0V	-	5	10	μA
V <sub>ENL</sub>	Enable Threshold	Logic-Low Voltage	-	-	0.3	V
V <sub>ENH</sub>		Logic-High Voltage	1.1	-	-	
<b>Power OK</b>						
POK_H	POK High Threshold	V <sub>FB</sub> Rising	-	92	-	%
POK_L	POK Low Threshold	V <sub>FB</sub> Falling	-	82	-	%
V <sub>POKL</sub>	POK Sink Voltage	Sink Current 5mA	-	-	0.4	V
t <sub>POK_DT</sub>	POK Delay Time	-	0.5	1.5	5	ms
<b>Thermal Protection</b>						
T <sub>SD</sub>	Thermal Shutdown Temperature	-	-	165	-	°C
ΔT <sub>SD</sub>	Thermal Shutdown Hysteresis	-	-	30	-	°C

## Typical Performance Characteristics

$V_{IN} = V_{CC} = 5V$ ,  $V_{OUT} = 0.8V$ ,  $C_{IN} = C_{OUT} = 10\mu F$  and  $T_A = 25^\circ C$ , unless otherwise specified.

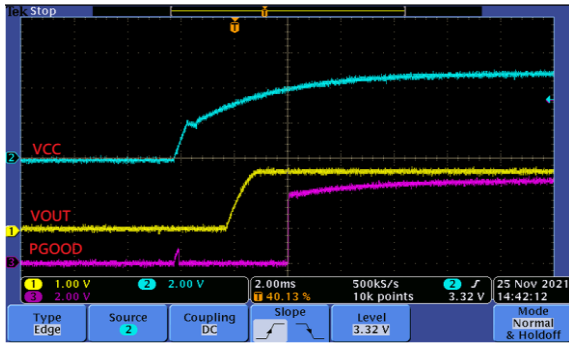

VCC Power ON,  $I_{OUT} = 200mA$

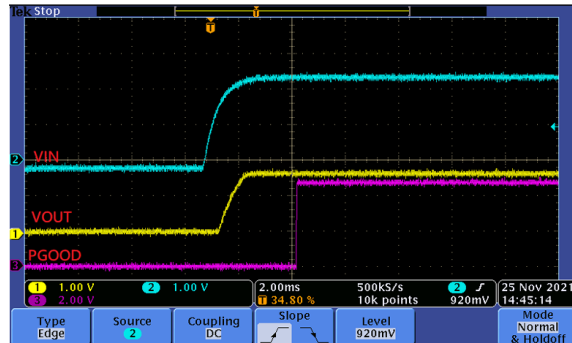

$V_{IN}$  Power ON,  $I_{OUT} = 200mA$

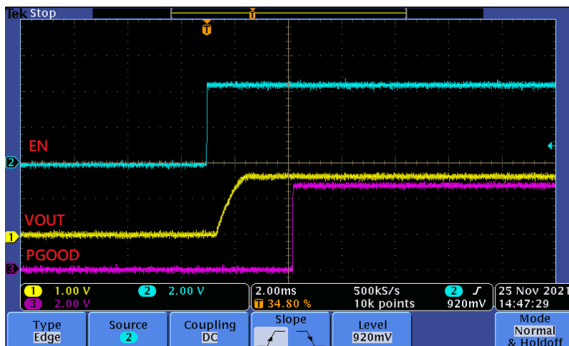

Enable ON,  $I_{OUT} = 200mA$

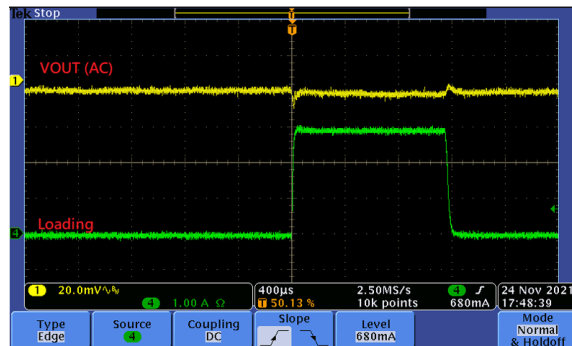

Load Transient,  $I_{OUT} = 0$  to  $3A$

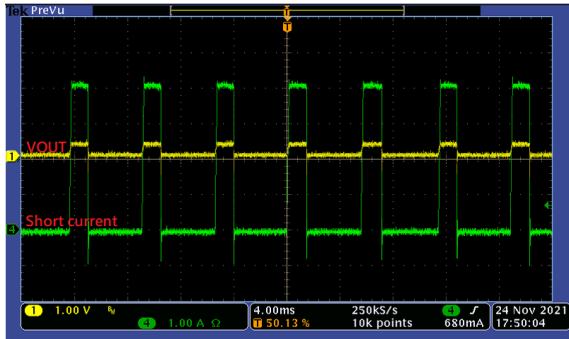

Short Circuit Waveform

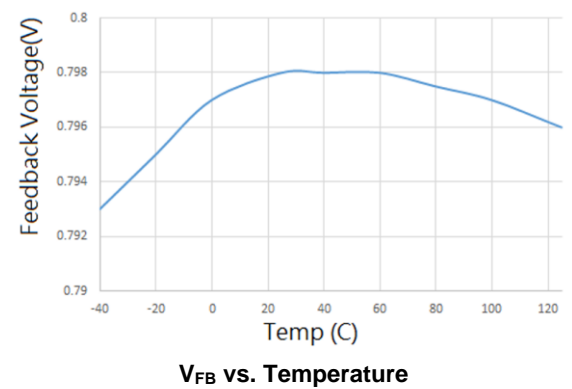
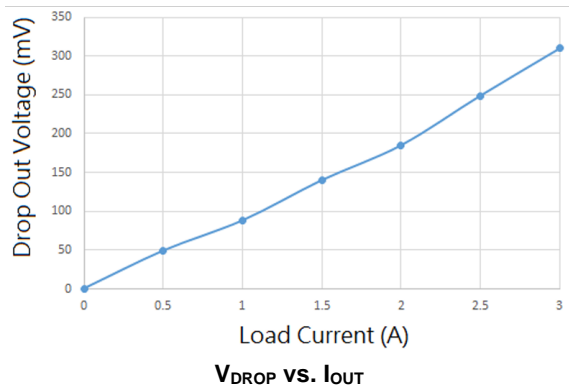

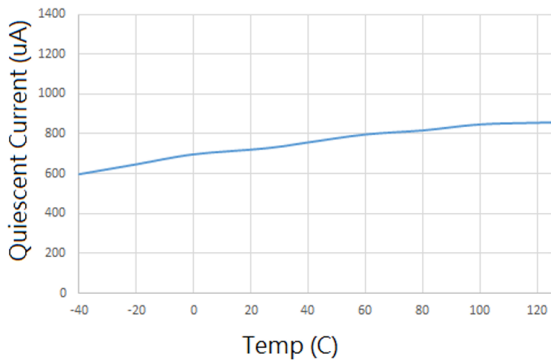

**IQ vs. Temperature**

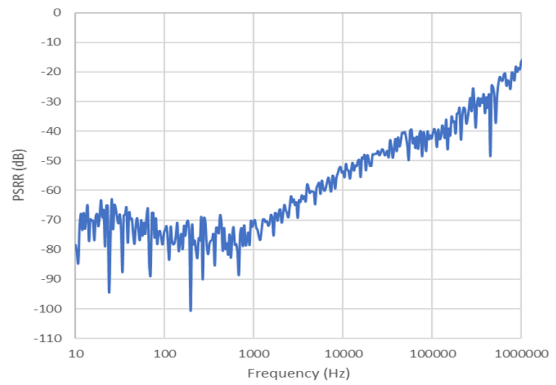

**PSRR**

(V<sub>CC</sub>=5V, V<sub>IN</sub>=3.3V, V<sub>OUT</sub>=1.6V and I<sub>OUT</sub>=1mA)

### Typical Application Circuit

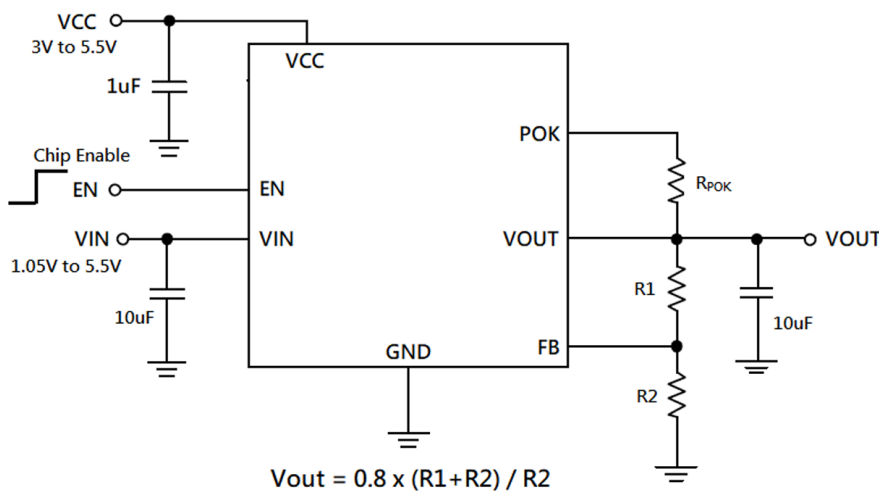

### Application Information

#### Output Voltage Setting

The output voltage is programmed by the resistor divider connected to the FB pin. The preset output voltage is calculated by the following equation :

$$V_{OUT} = 0.8 \cdot \left( 1 + \frac{R1}{R2} \right) \dots\dots\dots (V)$$

Where R1 is the resistor connected from V<sub>OUT</sub> to FB with Kelvin sensing connection and R2 is the resistor connected from FB to GND and the 10Kohm is recommended typically.

#### Enable Control

A logic Low signal applied to this pin shuts down the output. A logic High signal enables the device to output a regulated power when V<sub>CC</sub> and V<sub>IN</sub> power supplies are ready. Enable pin is pulled high to V<sub>CC</sub> internally.

#### Power-OK and Delay

The power okay pin is an open-drain output and a 100kΩ pull up resistor has to be used to connect between POK pin to V<sub>OUT</sub> to obtain an effective signal.

As the V<sub>FB</sub> rises and reaches the rising Power-OK voltage threshold, an internal delay function starts to work. At the end of the delay time, the POK output HIGH to indicate the output is ok.

As the V<sub>FB</sub> falls and reaches the falling Power-OK voltage threshold, the POK output LOW.

## Application Information (Continued)

### Power-On-Reset

A Power-On-Reset (POR) circuit monitors both of supply voltages on  $V_{CC}$  and  $V_{IN}$  pins to prevent wrong logic controls. The POR function initiates a soft-start process after both of the supply voltages exceed their rising POR voltage thresholds during powering on.

### Soft-Start

An internal soft-start function controls rise rate of the output voltage to limit the current surge during start-up. The typical soft-start interval is about 1.0ms.

### Current-Limit Protection

The GS2231A monitors the current flowing through the output NMOS and limits the maximum current to prevent load and GS2231A from damages during current overload conditions.

### Thermal Shutdown Protection

Thermal protection limits power dissipation to prevent IC over temperature.

When the junction temperature exceeds 165°C, the over temperature protection circuit starts the thermal shutdown function and turns the pass transistor off. The pass transistor turns on again after the junction temperature cools by 30°C.

## Package Information

### PSOP-8

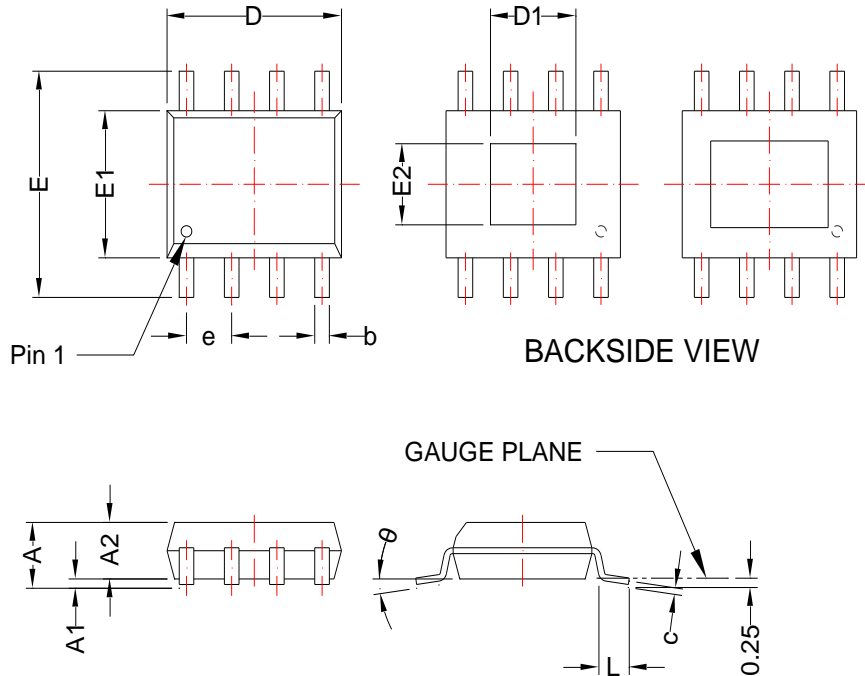

DIMENSION D DOES NOT INCLUDE MOLD FLASH, PROTRUSIONS OR GATE BURRS. MOLD FLASH, PROTRUSIONS OR GATE BURRS SHALL NOT EXCEED 0.15 mm PER END. DIMENSION E1 DOES NOT INCLUDE INTERLEAD FLASH OR PROTRUSION. INTERLEAD FLASH OR PROTRUSION SHALL NOT EXCEED 0.25 mm PER SIDE.

Dimensions				
SYMBOL	Millimeters		Inches	
	MIN	MAX	MIN	MAX
A	---	1.75	---	0.069
A1	0.10	0.15	0.004	0.006
A2	1.25	---	0.049	---
b	0.31	0.51	0.012	0.020
c	0.10	0.25	0.004	0.010
D	4.70	5.10	0.185	0.201
D1	1.50	---	0.059	---
E	5.80	6.20	0.228	0.244
E1	3.80	4.00	0.150	0.157
E2	1.00	---	0.039	---
e	1.27 BSC		0.050 BSC	
L	0.4	1.27	0.016	0.050
$\theta$	0°	8°	0°	8°



## Package Information

### DFN3X3-10

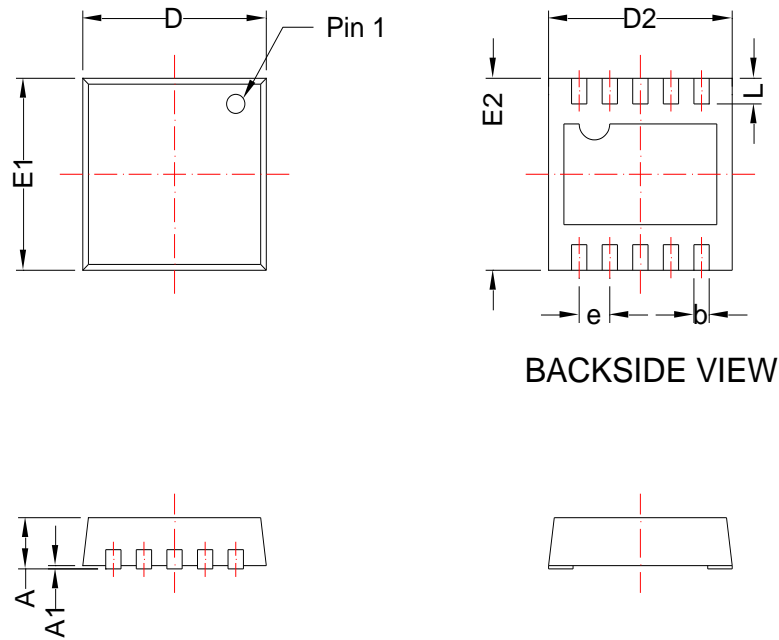

DIMENSION D AND E1 DO NOT INCLUDE MOLD FLASH, TIE BAR BURRS, GATE BURRS, AND INTERLEAD FLASH, NOT INCLUDING ANY MISMATCH BETWEEN THE TOP AND BOTTOM OF THE PLASTIC BODY

Dimensions				
SYMBOL	Millimeters		Inches	
	MIN	MAX	MIN	MAX
A	0.70	0.80	0.028	0.031
A1	0.00	0.05	0.000	0.002
b	0.18	0.30	0.007	0.012
D	2.90	3.10	0.114	0.122
D2	2.20	2.70	0.087	0.106
E1	2.90	3.10	0.114	0.122
E2	1.40	1.80	0.055	0.071
e	0.50 BSC		0.020 BSC	
L	0.30	0.50	0.012	0.020





## NOTICE



- Globaltech Semiconductor assumes no responsibility for equipment failures that result from using products at values that exceed, even momentarily, rated values (such as maximum ratings, operating condition ranges, or other parameters) listed in products specifications of any and all Globaltech Semiconductor products described or contained herein. Globaltech Semiconductor products are not designed for use in life support appliances, devices or systems where malfunction of these products can be reasonably expected to result in personal injury. Reproduction in whole or in part is prohibited without the prior written consent of the copyright owner.

- Applications shown on the herein document are examples of standard use and operation. Customers are responsible in comprehending the suitable use in particular applications. Globaltech Semiconductor makes no representation or warranty that such applications will be suitable for the specified use without further testing or modification.

- Information furnished is believed to be accurate and reliable. However Globaltech Semiconductor assumes no responsibility for the consequences of use of such information nor for any infringement of patents or other rights of third parties, which may result from its use. No license is granted by implication or otherwise under any patent or patent rights of Globaltech Semiconductor. Specifications mentioned in this publication are subject to change without notice. This publication supersedes and replaces all information without express written approval of Globaltech Semiconductor.

## CONTACT US

GS Headquarter	
	4F.,No.43-1,Lane11,Sec.6,Minquan E. Rd Neihu District Taipei City 114, Taiwan (R.O.C)
	886-2-2657-9980
	886-2-2657-3630
	sales_twn@gs-power.com

RD Division	
	824 Bolton Drive Milpitas. CA. 95035
	1-408-457-0587